

MTL4500/5500 range Intrinsically safe galvanic isolators

- **3-port isolation as standard**
- **Highest module/channel packing densities**
- **Low power dissipation**
- **Quick install and release mechanism**
- **Multi-channel I/O modules**
- **Broken line monitoring**
- **Compatible with preceding MTL isolator range for pluggable replacements**
- **Various models assessed for use in Functional Safety applications**

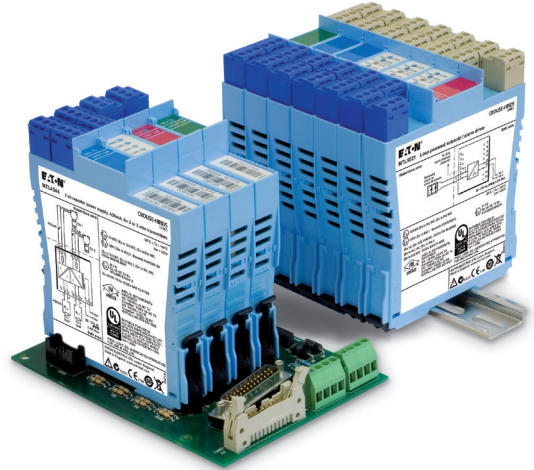

Eaton's latest generation of MTL IS interfaces utilises an innovative "One-Core" technology to ensure the highest quality and availability while maintaining maximum flexibility at lowest cost. Incorporating advanced circuit design, a common set of components and innovative isolating transformer construction, they achieve a significant reduction in power consumption while increasing channel packing densities. The compact, 16mm wide design reduces weight and gives exceptionally high packing density. They build on the proven success of the MTL2000, 3000, 4000 and 5000 range to bring the benefits of new developments in galvanic isolation without compromising the reliability of the designs from which they have evolved.

The backplane mounting MTL4500 range is designed with system vendors in mind for "project-focussed" applications such as Distributed Control System (DCS), Emergency Shutdown Systems (ESD) and Fire and Gas monitoring (F&G).

The reduced power consumption and high efficiency enable high signal density to be achieved together with improved freedom in cabinet layout and design. Easy integration with the input/output assemblies of control or safety instrumentation systems not only simplifies project engineering but also reduces installation and maintenance costs.

A multiway connector to the backplane provides safe-area and power supply connections, while hazardous-area connections plug into the front of the module, simplifying installation and maintenance and reducing time, cost, and the risk of errors.

The DIN-rail mounting MTL5500 range meets the needs of the IS interface market for "application focussed" projects, ranging from single instrument loops, through to fully equipped cabinets, across all industries where hazardous areas exist.

The MTL5500 clips quickly onto DIN rail, so it is compatible with the industry-standard mounting system. Wiring is simplified by plug-in safe- and hazardous-area connectors, and a power plug which accepts a power bus; it all leads to quicker insertion, fewer wiring errors and trouble-free, tidier installations.

Line fault detection (LFD) facilities are provided across the range of I/O functions; on the switch/proximity detectors, the MTL4523/5523 solenoid/alarm drivers and the isolating drivers. Analogue input units such as the MTL4541/5541 provide line fault detection by repeating o/c or s/c currents to the safe-area control system.

Status LEDs, configuration switches and ports are located on the top or side of individual modules, as appropriate, for easy access.

Both ranges have been designed for compatibility with earlier models. The MTL4500 range provides plug-replacements for the earlier MTL4000 units, while the MTL5500 range can easily replace MTL5000 units. Each offer the latest in modern technology and efficiency without compromise.

In addition to their use in IS circuits, specific models within the MTL4500 and MTL5500 range have been assessed and approved for use in Functional Safety applications. These have been verified under the certified Functional Safety Management (FSM) programme implemented by our MTL product line.

ISOLATOR FUNCTION SELECTOR



MTL4500 (Backplane)

Digital Input

MTL4501-SR
MTL4504
MTL4510
MTL4510B
MTL4511
MTL4513
MTL4514/B
MTL4514D
MTL4514N
MTL4516
MTL4516C
MTL4517

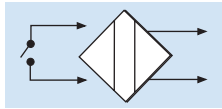

MTL5500 (DIN-rail)

MTL5501-SR
-
MTL5510
MTL5510B
MTL5511
MTL5513
MTL5514
MTL5514D
-
-
MTL5516C
MTL5517

FSM

✓
✓

✓

✓
✓
✓
✓
✓
✓
✓
✓
✓

Channels Function

1 fail-safe solid-state output + LFD alarm
1 switch/prox input, phase reversal + LFD
4 switch/prox input, solid-state output
4 multi-function switch/prox input, solid-state output
1 switch/prox input, c/o relay output
2 switch/prox input, solid-state output
1 switch/prox input, relay + LFD
1 switch/prox input, dual output relay
1 switch/prox input, relay + LFD
2 switch/prox input, relay + LFD outputs
2 switch/prox input, c/o relay + LFD outputs
2 switch/prox input, relay + LFD outputs

Digital Output

MTL4521
MTL4521L
-
MTL4523
MTL4523L
MTL4523R
MTL4523V
MTL4524
MTL4524S
MTL4525
MTL4526

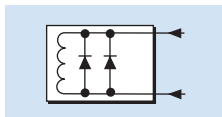

MTL5521
-
MTL5522
MTL5523
-
-
MTL5523V
MTL5524
-
MTL5525
MTL5526

✓
✓
✓
✓
✓
✓
✓
✓
✓
✓
✓
✓

1 loop powered solenoid driver
1 loop powered solenoid driver, IIC
1 loop powered solenoid driver, IIB
1 solenoid driver with LFD
1 loop powered solenoid driver with LFD
1 solenoid driver with reverse LFD
1 solenoid driver with LFD, IIC
1 switch operated solenoid driver
1 switch operated solenoid driver, 24V override
1 switch operated solenoid driver, low power
2 switch operated relay

Pulse & Vibration

MTL4531
MTL4532
-

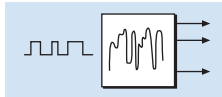

MTL5531
MTL5532
MTL5533

✓

✓

1 vibration probe interface
1 pulse isolator, digital or analogue output
2 vibration probe interface

Analogue Input

MTL4541
MTL4541A
MTL4541AS
MTL4541S
MTL4541T
MTL4544
MTL4544A
MTL4544AS
MTL4544S
MTL4544D

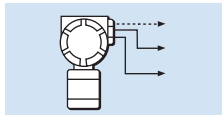

MTL5541
MTL5541A
MTL5541AS
MTL5541S
-
MTL5544
MTL5544A
MTL5544AS
MTL5544S
MTL5544D

✓
✓
✓
✓

✓
✓
✓
✓
✓
✓

1 2/3 wire transmitter repeater
1 transmitter repeater, passive input
1 transmitter repeater, passive input, current sink
1 2/3 wire transmitter repeater, current sink
1 2/3 wire transmitter repeater, long cables
2 2/3 wire transmitter repeater
2 transmitter repeater, passive input
2 transmitter repeater, passive input, current sink
2 2/3 wire transmitter repeater, current sink
1 2/3 wire transmitter repeater, dual output

Analogue Output

MTL4546
MTL4546S
MTL4546Y
MTL4549
MTL4549Y

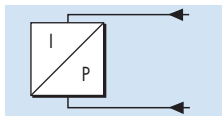

MTL5546
-
MTL5546Y
MTL5549
MTL5549Y

✓

✓
✓
✓
✓

1 4-20mA smart isolating driver + LFD
1 4-20mA smart isolating driver + LFD
1 4-20mA smart isolating driver + oc LFD
2 4-20mA smart isolating driver + LFD
2 4-20mA smart isolating driver + oc LFD

Fire & Smoke

MTL4561

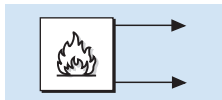

MTL5561

✓

2 loop-powered, for fire and smoke detectors

Temperature Input

MTL4573
MTL4575
MTL4576-RTD
MTL4576-THC
MTL4581
-

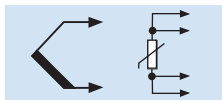

MTL5573
MTL5575
MTL5576-RTD
MTL5576-THC
MTL5581
MTL5582

✓

1 temperature converter, THC or RTD
1 temperature converter, THC or RTD
2 temperature converter, RTD
2 temperature converter, THC
1 mV/mV isolator
1 RTD/RTD isolator

General

MTL4599
MTL4599N

MTL5599
-

-
-

dummy module
general purpose feed-through module



Powering Business Worldwide

Eaton Electric Limited,
Great Marlings, Butterfield, Luton
Beds, LU2 8DL, UK.
Tel: + 44 (0)1582 723633 Fax: + 44 (0)1582 422283
E-mail: mtl-enquiry@eaton.com
www.mtl-inst.com

© 2016 Eaton
All Rights Reserved
Publication No.
EPS45/5500 Rev12 010916

EUROPE (EMEA):
+44 (0)1582 723633 mtl-enquiry@eaton.com
THE AMERICAS:
+1 800 835 7075 mtl-us-info@eaton.com
ASIA-PACIFIC:
+65 6 645 9888 sales.mtling@eaton.com

MTL4501-SR – MTL5501-SR FAIL-SAFE SWITCH/PROXIMITY- DETECTOR INTERFACE with LFD

With the MTLx501-SR, a fail-safe switch/proximity detector located in the hazardous area can control an isolated fail-safe electronic output. The MTLx501-SR also provides relay alarm contacts to signal line-fault conditions. The MTLx501-SR is for use with approved fail-safe sensors in loops that require operation up to SIL3 according to the functional safety standard IEC 61508.

SPECIFICATION

See also common specification

Number of channels

One

Location of switches

Zone 0, IIC, T6 hazardous area
Div. 1, Group A hazardous location

Location of proximity detector

Zone 0, IIC, T4–6, hazardous location
Div 1, Group A, hazardous location

Voltage applied to sensor

8.6V dc max from 1k Ω

Input/output characteristics

| Input value in sensor circuits | Fail-safe output | Operation | LFD contacts |
|--|------------------|--------------|--------------|
| $2.9\text{mA} < I_s < 3.9\text{mA}$ | ON | Normal | CLOSED |
| $I_s < 1.9\text{mA} \ \& \ I_s > 5.1\text{mA}$ | OFF | Normal | CLOSED |
| $I_s < 50\mu\text{A}$ | OFF | Broken line | OPEN |
| $R_s < 100\Omega$ | OFF | Shorted line | OPEN |

Note: I_s = sensor current

Fail-safe electronic output

Output on: 24V nominal
Output off: 0V dc, max < 5V dc
Load: 750 Ω to 10k Ω
Maximum on-state current: 25mA (at 750 Ω)
Short-circuit current: 30mA

Line fault detection (LFD)

LFD relay output: contacts open when line fault detected
Switch characteristics: 0.3A 110V ac/dc; 1A 35V dc; 30W/33VA

LED indicators

Green: power indication
Yellow: channel status, on when fail-safe output energised
Red: LFD indication, flashing when line fault detected



MTL4501-SR

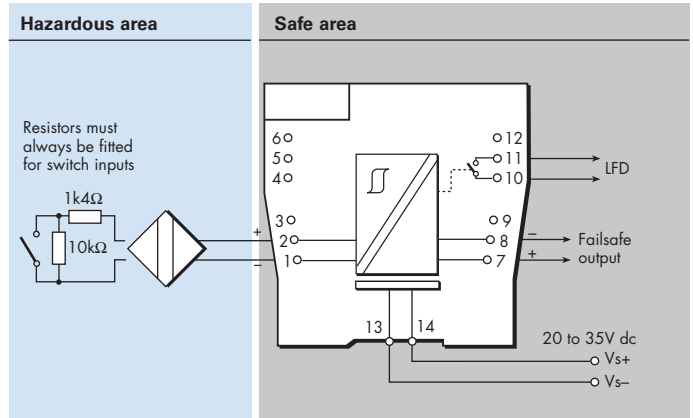

MTL5501-SR

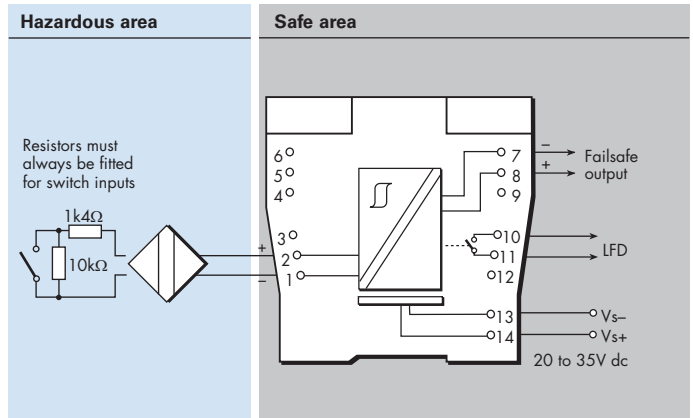

Power requirements, V_s

| @ Supply voltage | 750 Ω load | typ. load |
|------------------|-------------------|-----------|
| 20V dc | 100mA | 70mA |
| 24V dc | 90mA | 60mA |
| 35V dc | 65mA | 45mA |

Power dissipation within unit

| @ Supply voltage | 750 Ω load | typ. load |
|------------------|-------------------|-----------|
| 20V dc | 1232mW | 1160mW |
| 24V dc | 1392mW | 1200mW |
| 35V dc | 1507mW | 1335mW |

Safety description

$U_o = \pm 9.7\text{V}$, $I_o = 30\text{mA}$, $P_o = 0.07\text{W}$, $C_i = 0\text{nF}$, $L_i = 0\text{mH}$
 $U_m = 253\text{V}$



SIL capable

Highest level in single in-line subsystem - SIL3 (in accordance with IEC61508-2)
See data on MTL web site and refer to the safety manual.



Powering Business Worldwide

Eaton Electric Limited,
Great Marlings, Butterfield, Luton
Beds, LU2 8DL, UK.
Tel: + 44 (0)1582 723633 Fax: + 44 (0)1582 422283
E-mail: mtlenquiry@eaton.com
www.mtl-inst.com

© 2016 Eaton
All Rights Reserved
Publication No.
EPSx501SR Rev5 010916

EUROPE (EMEA):
+44 (0)1582 723633 mtlenquiry@eaton.com
THE AMERICAS:
+1 800 835 7075 mtl-us-info@eaton.com
ASIA-PACIFIC:
+65 6 645 9888 sales.mtlsing@eaton.com

The given data is only intended as a product description and should not be regarded as a legal warranty of properties or guarantee.
In the interest of further technical developments, we reserve the right to make design changes.

MTL4504 SWITCH/ PROXIMITY DETECTOR INTERFACE

1-channel with LFD and phase reversal

The MTL4504 enables a safe-area load to be controlled, through a relay, by a proximity detector or switch located in a hazardous area. Line faults are signalled through a separate relay and indicated on the top of the module. MTBF information for the LFD relay is available from Eaton to allow the failure rate for the LFD relay to be calculated when used in the critical path with the output relay for safety critical applications. Switches are provided to select phase reversal and to enable the line fault detection.

SPECIFICATION

See also common specification

Number of channels

One

Location of switch

Zone 0, IIC, T6 hazardous area
Div.1, Group A, hazardous location

Location of proximity detector

Zone 0, IIC, T4–6 hazardous area, if suitably certified
Div.1, Group A, hazardous location

Hazardous-area inputs

Inputs conforming to BS EN60947–5–6:2001 standards for proximity detectors (NAMUR)

Voltage applied to sensor

7 to 9V dc from $1k\Omega \pm 10\%$

Input/output characteristics

Normal phase

Outputs closed if input $> 2.1mA$ ($< 2k\Omega$ in input circuit)

Outputs open if input $< 1.2mA$ ($> 10k\Omega$ in input circuit)

Hysteresis: $200\mu A$ (650Ω) nominal

Line fault detection (LFD) (when selected)

User-selectable via switches on the side of the unit. Line faults are indicated by an LED. Line fault relay is de-energised and channel output relay de-energised if input line-fault detected

Open-circuit alarm on if $I_{in} < 50\mu A$

Open-circuit alarm off if $I_{in} > 250\mu A$

Short-circuit alarm on if $R_{in} < 100\Omega$

Short-circuit alarm off if $R_{in} > 360\Omega$

Note: Resistors must be fitted when using the LFD facility with a contact input
 500Ω to $1k\Omega$ in series with switch
 $20k\Omega$ to $25k\Omega$ in parallel with switch

Safe-area output

Channel: Single pole relay with changeover contacts

LFD: Single pole relay with changeover contacts

Note: reactive loads must be adequately suppressed

MTL4504

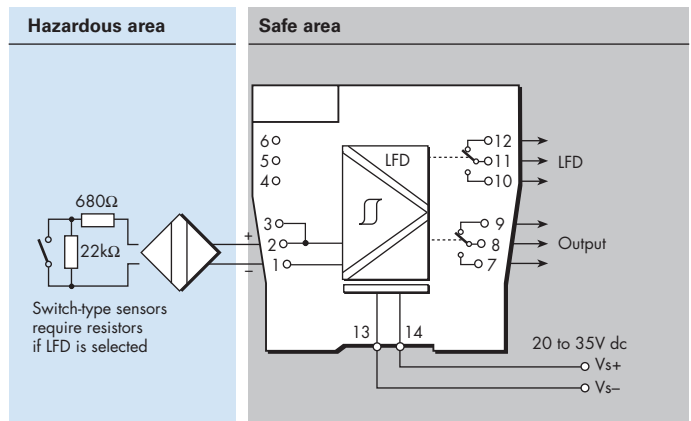

Relay characteristics

Response time: 10ms maximum

Contact rating: 10W, 0.5A, 35V dc

LED indicators

Green: power indication

Yellow: channel status, on when output energised

Red: LFD indication, on when line fault detected

Maximum current consumption

25mA at 24V dc

Power dissipation within unit

0.6W at 24V

Safety description

$U_o=10.5V$ $I_o=14mA$ $P_o=37mW$ $U_m = 253V$ rms or dc



SIL capable

These models have been assessed for use in IEC 61508 functional safety applications.

SIL2 capable for a single device (HFT=0)

SIL3 capable for multiple devices in safety redundant configurations (HFT=1)

See data on MTL web site and refer to the safety manual.



Powering Business Worldwide

Eaton Electric Limited,

Great Marlings, Butterfield, Luton
Beds, LU2 8DL, UK.

Tel: + 44 (0)1582 723633 Fax: + 44 (0)1582 422283

E-mail: mtlenquiry@eaton.com

www.mtl-inst.com

© 2016 Eaton

All Rights Reserved

Publication No.

EPS4504 Rev5 010916

EUROPE (EMEA):

+44 (0)1582 723633 mtlenquiry@eaton.com

THE AMERICAS:

+1 800 835 7075 mtl-us-info@eaton.com

ASIA-PACIFIC:

+65 6 645 9888 sales.mtlsing@eaton.com

The given data is only intended as a product description and should not be regarded as a legal warranty of properties or guarantee.

In the interest of further technical developments, we reserve the right to make design changes.

MTL4510 – MTL5510 SWITCH/ PROXIMITY DETECTOR INTERFACE

4-channel, digital input

The MTLx510 enables four solid-state outputs in the safe area to be controlled by up to four switches or proximity detectors located in a hazardous area. Each pair of output transistors shares a common terminal and can switch +ve or –ve polarity signals. A range of module configurations is available (see Table 1) through the use of selector switches. When proximity detector modes are selected, LFD is enabled and the output switches to OFF if a line fault is detected.

SPECIFICATION

See also common specification

Number of channels

4, configured by switches

Location of switches

Zone 0, IIC, T6 hazardous area
Div 1, Group A hazardous location

Location of proximity detectors

Zone 0, IIC, T4-6 hazardous area if suitably certified
Div 1, Group A, hazardous location

Hazardous-area inputs

Inputs conforming to BS EN60947-5-6:2001 standards for proximity detectors (NAMUR)

Voltage applied to sensor

7 to 9V dc from 1k Ω \pm 10%

Input/output characteristics

Normal phase

Outputs closed if input > 2.1mA (< 2k Ω in input circuit)
Outputs open if input < 1.2mA (> 10k Ω in input circuit)
Hysteresis: 200 μ A (650 Ω) nominal

Line fault detection (LFD) (when selected)

User-selectable via switches on the side of the unit.

Open-circuit alarm on if $I_{in} < 50\mu$ A

Open-circuit alarm off if $I_{in} > 250\mu$ A

Short-circuit alarm on if $R_{in} < 100\Omega$

Short-circuit alarm off if $R_{in} > 360\Omega$

Note: Resistors must be fitted when using the LFD facility with a contact input
500 Ω to 1k Ω in series with switch
20k Ω to 25k Ω in parallel with switch

Safe-area outputs

Floating solid-state outputs compatible with logic circuits

Operating frequency: dc to 500Hz

Max. off-state voltage: \pm 35V

Max. off-state leakage current: \pm 50 μ A

Max. on-state resistance: 25 Ω

Max. on-state current: \pm 50mA

LED indicators

Green: power indication

Yellow: four: on when output active

Red: LFD indication + faulty channel's yellow LED flashes

Maximum current consumption

40mA at 24V (with all output channels energised)

Power dissipation within unit

0.96W at 24V, with 10mA loads

Safety description (each channel)

$U_o=10.5V$ $I_o=14mA$ $P_o=37mW$ $U_m = 253V$ rms or dc

MTL4510

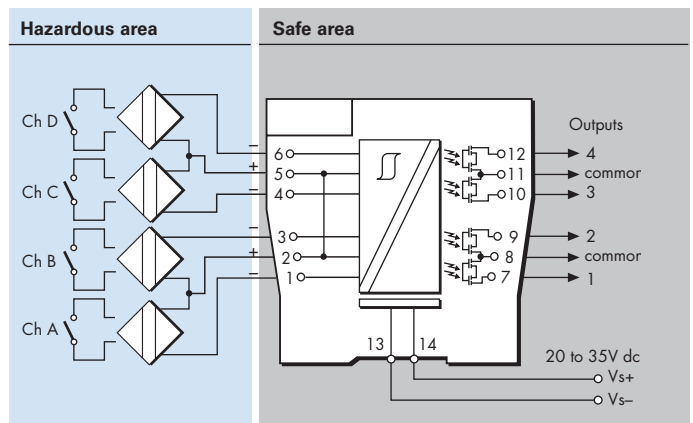

MTL5510

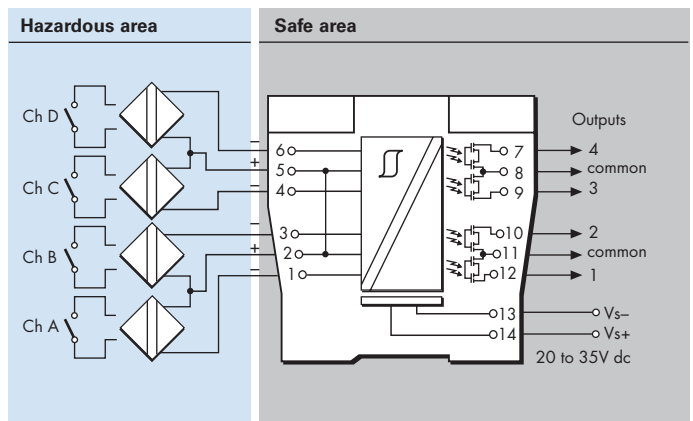

Table 1 - Mode options

| MODE | o/p 1 | o/p 2 | o/p 3 | o/p 4 | i/p type |
|------|----------|----------|----------|----------|----------------------|
| 0 | chA | chB | chC | chD | switch |
| 1 | chA rev. | chB | chC | chD | |
| 2 | chA | chB rev. | chC | chD | |
| 3 | chA | chB | chC rev. | chD | |
| 4 | chA | chB | chC | chD rev. | |
| 5 | chA rev. | chB | chC rev. | chD | |
| 6 | chA | chB rev. | chC | chD rev. | |
| 7 | chA rev. | chB rev. | chC rev. | chD rev. | prox. detector + LFD |
| 8 | chA | chB | chC | chD | |
| 9 | chA rev. | chB | chC | chD | |
| 10 | chA | chB rev. | chC | chD | |
| 11 | chA | chB | chC rev. | chD | |
| 12 | chA | chB | chC | chD rev. | |
| 13 | chA rev. | chB | chC rev. | chD | |
| 14 | chA | chB rev. | chC | chD rev. | |
| 15 | chA rev. | chB rev. | chC rev. | chD rev. | |

See Instruction Manual INM4500 or INM5500 for further mode information.



Powering Business Worldwide

Eaton Electric Limited,

Great Marlings, Butterfield, Luton
Beds, LU2 8DL, UK.
Tel: + 44 (0)1582 723633 Fax: + 44 (0)1582 422283
E-mail: mtlenquiry@eaton.com
www.mtl-inst.com

© 2016 Eaton
All Rights Reserved
Publication No.
EPSx510 Rev4 010916

EUROPE (EMEA):

+44 (0)1582 723633 mtlenquiry@eaton.com

THE AMERICAS:

+1 800 835 7075 mtl-us-info@eaton.com

ASIA-PACIFIC:

+65 6 645 9888 sales.mtlsing@eaton.com

The given data is only intended as a product description and should not be regarded as a legal warranty of properties or guarantee.

In the interest of further technical developments, we reserve the right to make design changes.

MTL4510B – MTL5510B SWITCH/ PROXIMITY DETECTOR INTERFACE

4-channel, multi-function, digital input

The MTL4510B enables four solid-state outputs in the safe area to be controlled by up to four switches or proximity detectors located in a hazardous area. Each pair of output transistors shares a common terminal and can switch +ve or -ve polarity signals. A range of module configurations is available (see Table 1) through the use of selector switches. These include start/stop operations and pulse output modes.

SPECIFICATION

See also common specification

Number of channels

4, configured by switches

Location of switches

Zone 0, IIC, T6 hazardous area
Div 1, Group A hazardous location

Location of proximity detectors

Zone 0, IIC, T4-6 hazardous area if suitably certified
Div 1, Group A, hazardous location

Hazardous-area inputs

Inputs conforming to BS EN60947-5-6:2001 standards for proximity detectors (NAMUR)

Voltage applied to sensor

7 to 9V dc from 1k Ω \pm 10%

Input/output characteristics

Normal phase

Outputs closed if input > 2.1mA (< 2k Ω in input circuit)

Outputs open if input < 1.2mA (> 10k Ω in input circuit)

Hysteresis: 200 μ A (650 Ω) nominal

Line fault detection (LFD) (when selected)

User-selectable via switches on the side of the unit.

Open-circuit alarm on if $I_{in} < 50\mu$ A

Open-circuit alarm off if $I_{in} > 250\mu$ A

Short-circuit alarm on if $R_{in} < 100\Omega$

Short-circuit alarm off if $R_{in} > 360\Omega$

Note: Resistors must be fitted when using the LFD facility with a contact input
500 Ω to 1k Ω in series with switch
20k Ω to 25k Ω in parallel with switch

Safe-area outputs

Floating solid-state outputs compatible with logic circuits

Operating frequency: dc to 500Hz

Max. off-state voltage: \pm 35V

Max. off-state leakage current: \pm 50 μ A

Max. on-state resistance: 25 Ω

Max. on-state current: \pm 50mA

LED indicators

Green: power indication

Yellow: four: on when output active

Red: LFD indication + faulty channel's yellow LED flashes

Maximum current consumption

40mA at 24V (with all output channels energised)

Power dissipation within unit

0.96W at 24V, with 10mA loads

Safety description (each channel)

$U_o=10.5V$ $I_o=14mA$ $P_o=37mW$ $U_m = 253V$ rms or dc

MTL4510B

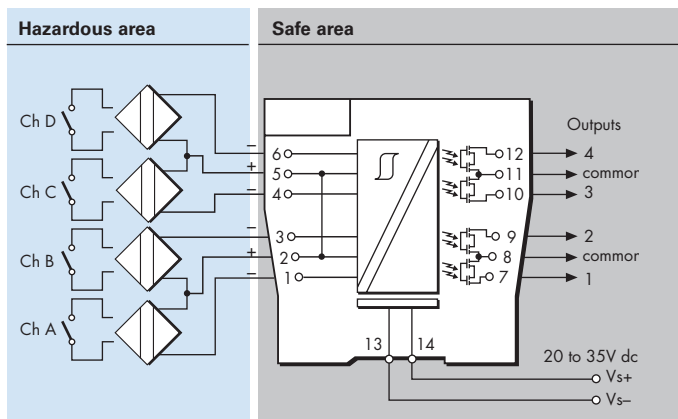

MTL5510B

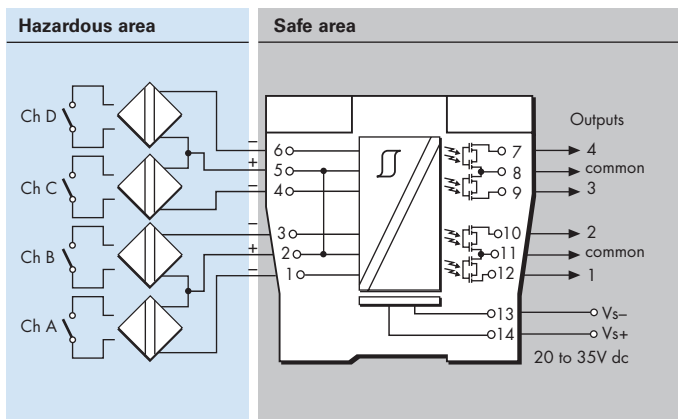

Table 1 - Mode options

| MODE | Function | Equivalent* |
|------|---|-------------|
| 0 | 4-ch switch input, | MTLx510 |
| 1 | 2-ch each channel one input, two outputs | MTL4016 |
| 2 | As mode 1 but with phase of one output reversed | MTL4016 |
| 3 | 2-ch, 2-pole changeover output | |
| 4 | 1-ch with line fault output | MTLx014 |
| 5 | As mode 4 with changeover outputs | |
| 6 | 1-ch with start-stop latch | MTL2210B |
| 7 | 4-ch switch input, | MTLx510 |
| 8 | 4-ch switch input, | MTLx510 |
| 9 | 2-ch with line fault output | MTLx017 |
| 10 | As mode 9 with LFD changeover | |
| 11 | As mode 10 with phase reversed | |
| 12 | 3-ch with normally-open LFD output | |
| 13 | 3-ch with normally-closed LFD output | |
| 14 | 2-ch monostable, pulse stretcher | |
| 15 | 4-ch switch input | MTLx510 |

* Note: that terminal connections may not be the same on these models, and x can mean either '4' or '5'.
See Instruction Manual INM4500 or INM5500 for further mode information.

The given data is only intended as a product description and should not be regarded as a legal warranty of properties or guarantee.
In the interest of further technical developments, we reserve the right to make design changes.



Powering Business Worldwide

Eaton Electric Limited,

Great Marlings, Butterfield, Luton
Beds, LU2 8DL, UK.
Tel: + 44 (0)1582 723633 Fax: + 44 (0)1582 422283
E-mail: mtlenquiry@eaton.com
www.mtl-inst.com

© 2016 Eaton
All Rights Reserved
Publication No.
EPSx510B Rev4 010916

EUROPE (EMEA):

+44 (0)1582 723633 mtlenquiry@eaton.com

THE AMERICAS:

+1 800 835 7075 mtl-us-info@eaton.com

ASIA-PACIFIC:

+65 6 645 9888 sales.mtlsing@eaton.com

MTL4511 – MTL5511 SWITCH/ PROXIMITY DETECTOR INTERFACE

1-channel, with line fault detection

The MTLx511 enables a safe-area load to be controlled by a switch or proximity detector located in a hazardous-area. When selected, open or short circuit conditions in the field wiring are detected by the line-fault-detect (LFD) facility and also indicated on the top of the module. Phase reversal for the channel is selected by a switch on the side of the module and output is provided by changeover relay contacts.

SPECIFICATION

See also common specification



Number of channels

One

Location of switches

Zone 0, IIC, T6 hazardous area
Div. 1, Group A hazardous location

Location of proximity detector

Zone 0, IIC, T4–6 hazardous area if suitably certified
Div. 1, Group A hazardous location

Hazardous-area inputs

Inputs conforming to BS EN60947–5–6:2001 standards for proximity detectors (NAMUR)

Voltage applied to sensor

7 to 9V dc from 1kΩ ±10%

Input/output characteristics

Normal phase

Outputs closed if input > 2.1mA (< 2kΩ in input circuit)

Outputs open if input < 1.2mA (> 10kΩ in input circuit)

Hysteresis: 200µA (650Ω) nominal

Line fault detection (LFD) (when selected)

User-selectable via switches on the side of the unit. A line fault is indicated by an LED. The channel output relay is de-energised if an input line fault is detected.

Open-circuit alarm on if $I_{in} < 50\mu A$

Open-circuit alarm off if $I_{in} > 250\mu A$

Short-circuit alarm on if $R_{in} < 100\Omega$

Short-circuit alarm off if $R_{in} > 360\Omega$

Note: Resistors must be fitted when using the LFD facility with a contact input
500Ω to 1kΩ in series with switch
20kΩ to 25kΩ in parallel with switch

Safe-area output

Single pole relay with changeover contacts

Note: reactive loads must be adequately suppressed

Relay characteristics

| | MTL4511 | MTL5511 |
|-----------------------------|-------------------|--|
| Response time: | 10ms maximum | 10ms maximum |
| Contact rating (Safe Area): | 10W, 0.5A, 35V dc | 250V ac, 2A, cosØ >0.7, 40V dc, 2A, resistive load |
| Contact rating (Zone 2): | 10W, 0.5A, 35V dc | 35V, 2A, 100VA. |

MTL4511

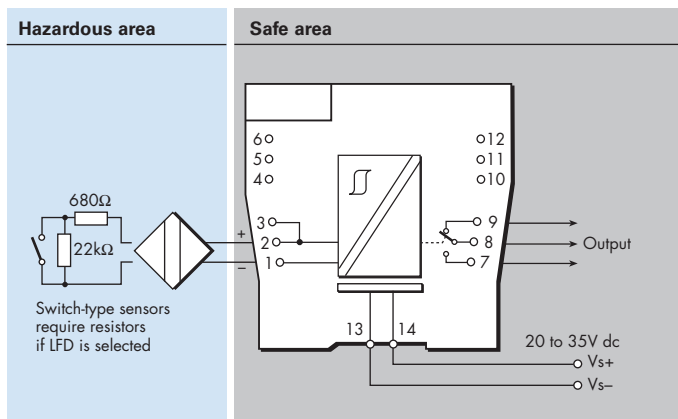

MTL5511

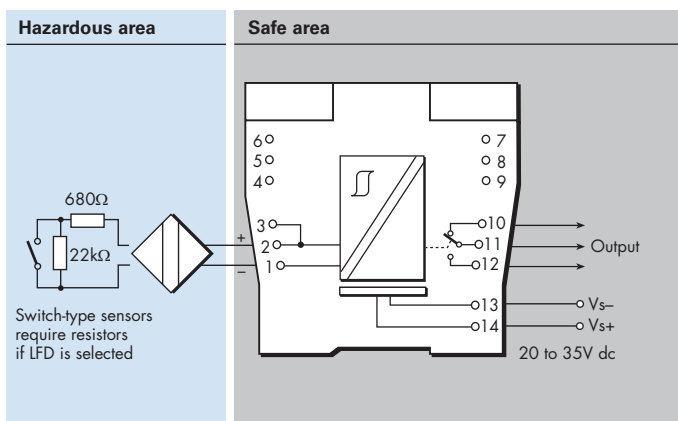

LED indicators

Green: power indication

Yellow: channel status, on when output energised

Red: LFD indication, on when line fault detected

Maximum current consumption

25mA at 24V

Power dissipation within unit

0.6W at 24V

Safety description (each channel)

$U_o=10.5V$ $I_o=14mA$ $P_o=37mW$ $U_m=253V$ rms or dc



SIL capable

These models have been assessed for use in IEC 61508 functional safety applications.

SIL2 capable for a single device (HFT=0)

SIL3 capable for multiple devices in safety redundant configurations (HFT=1)

See data on MTL web site and refer to the safety manual.

The given data is only intended as a product description and should not be regarded as a legal warranty of properties or guarantee. In the interest of further technical developments, we reserve the right to make design changes.



Powering Business Worldwide

Eaton Electric Limited,

Great Marlings, Butterfield, Luton Beds, LU2 8DL, UK.
Tel: + 44 (0)1582 723633 Fax: + 44 (0)1582 422283
E-mail: mtlenquiry@eaton.com
www.mtl-inst.com

© 2016 Eaton
All Rights Reserved
Publication No.
EPSx511 Rev6 010916

EUROPE (EMEA):

+44 (0)1582 723633 mtlenquiry@eaton.com

THE AMERICAS:

+1 800 835 7075 mtl-us-info@eaton.com

ASIA-PACIFIC:

+65 6 645 9888 sales.mtlsing@eaton.com

MTL4513 – MTL5513 SWITCH/ PROXIMITY DETECTOR INTERFACE

2-channel, line fault detection, phase reversal

The MTLx513 enables two solid-state outputs in the safe area to be controlled by two switches or proximity detectors located in the hazardous area. The Ch1/Ch2 output transistors share a common terminal and can switch +ve or -ve polarity signals. Independent output phase reversal and line fault detection are enabled via switches for each output. LFD indication is provided on the top of the module.

SPECIFICATION

See also common specification

Number of channels

Two

Location of switches

Zone 0, IIC, T6 hazardous area
Div. 1, Group A hazardous location

Location of proximity detectors

Zone 0, IIC, T4–6 hazardous area if suitably certified
Div. 1, Group A hazardous location

Hazardous-area inputs

Inputs conforming to BS EN60947–5–6:2001 standards for proximity detectors (NAMUR)

Voltage applied to sensor

7 to 9V dc from 1k Ω \pm 10%

Input/output characteristics

Normal phase

Outputs closed if input > 2.1mA (< 2k Ω in input circuit)

Outputs open if input < 1.2mA (> 10k Ω in input circuit)

Hysteresis: 200 μ A (650 Ω) nominal

Line fault detection (LFD) (when selected)

User-selectable for each channel via switches on the side of the unit. Line faults are indicated by an LED for each channel.

Open-circuit alarm on if $I_{in} < 50\mu$ A

Open-circuit alarm off if $I_{in} > 250\mu$ A

Short-circuit alarm on if $R_{in} < 100\Omega$

Short-circuit alarm off if $R_{in} > 360\Omega$

Note: Resistors must be fitted when using the LFD facility with a contact input
500 Ω to 1k Ω in series with switch
20k Ω to 25k Ω in parallel with switch

Phase reversal

Independent for each channel, user-selectable

Safe-area outputs

Floating solid-state outputs compatible with logic circuits

Operating frequency: dc to 500Hz

Max. off-state voltage: \pm 35V

Max. off-state leakage current: \pm 50 μ A

Max. on-state resistance: 25 Ω

Max. on-state current: \pm 50mA

MTL4513

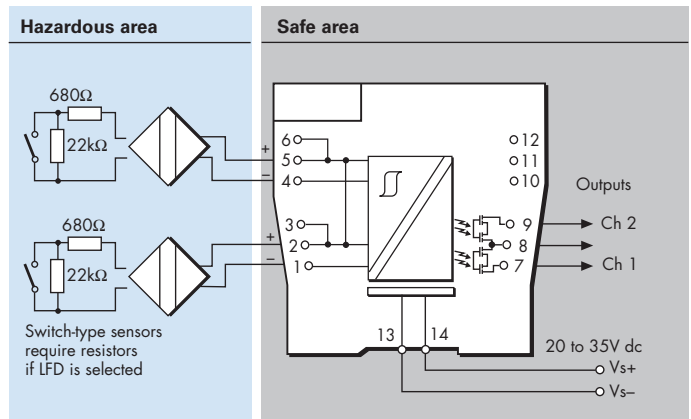

MTL5513

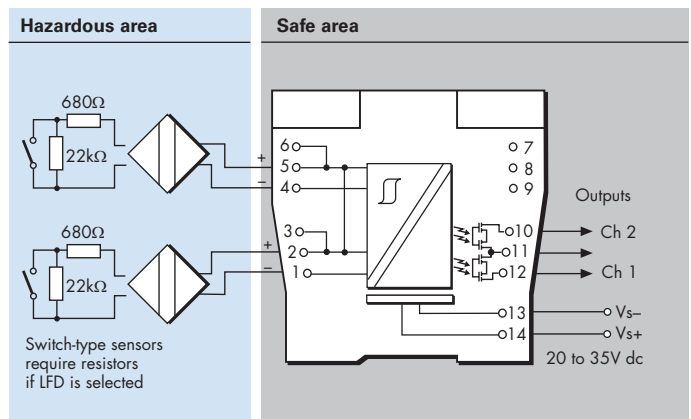

LED indicators

Green: power indication

Yellow: two: channel status, on when output active

Red: two: LFD indication, on when line fault detected

Maximum current consumption

30mA at 24V

Power dissipation within unit

0.65W typical at 24V, with 10mA loads

0.78W max. with 50mA loads

Safety description (each channel)

$U_o=10.5V$ $I_o=14mA$ $P_o=37mW$ $U_m = 253V$ rms or dc

The given data is only intended as a product description and should not be regarded as a legal warranty of properties or guarantee. In the interest of further technical developments, we reserve the right to make design changes.



Powering Business Worldwide

Eaton Electric Limited,

Great Marlings, Butterfield, Luton
Beds, LU2 8DL, UK.

Tel: + 44 (0)1582 723633 Fax: + 44 (0)1582 422283

E-mail: mtlenquiry@eaton.com

www.mtl-inst.com

© 2016 Eaton

All Rights Reserved

Publication No.

EPSx513 Rev5 010916

EUROPE (EMEA):

+44 (0)1582 723633 mtlenquiry@eaton.com

THE AMERICAS:

+1 800 835 7075 mtl-us-info@eaton.com

ASIA-PACIFIC:

+65 6 645 9888 sales.mtlsing@eaton.com

MTL4514/B – MTL5514 SWITCH/ PROXIMITY DETECTOR INTERFACE

1-channel, line fault detection, phase reversal

The MTLx514 enables a safe-area load to be controlled, through a relay, by a proximity detector or switch located in a hazardous area. Line faults are signalled through a separate relay and indicated on the top of the module. Switches are provided to select phase reversal and to enable the line fault detection.

SPECIFICATION

See also common specification



Number of channels

One

Location of switch

Zone 0, IIC, T6 hazardous area
Div.1, Group A, hazardous location

Location of proximity detector

Zone 0, IIC, T4–6 hazardous area, if suitably certified
Div.1, Group A, hazardous location

Hazardous-area inputs

Inputs conforming to BS EN60947–5–6:2001 standards for proximity detectors (NAMUR)

Voltage applied to sensor

7 to 9V dc from $1k\Omega \pm 10\%$

Input/output characteristics

Normal phase

Outputs closed if input $> 2.1mA$ ($< 2k\Omega$ in input circuit)
Outputs open if input $< 1.2mA$ ($> 10k\Omega$ in input circuit)

Hysteresis: $200\mu A$ (650Ω) nominal

Line fault detection (LFD) (when selected)

User-selectable via switches on the side of the unit. Line faults are indicated by an LED. Line fault relay is energised and channel output relay de-energised if input line-fault detected

Open-circuit alarm on if $I_{in} < 50\mu A$

Open-circuit alarm off if $I_{in} > 250\mu A$

Short-circuit alarm on if $R_{in} < 100\Omega$

Short-circuit alarm off if $R_{in} > 360\Omega$

Note: Resistors must be fitted when using the LFD facility with a contact input 500Ω to $1k\Omega$ in series with switch
 $20k\Omega$ to $25k\Omega$ in parallel with switch

Safe-area output

MTL4514 & MTL5514

Channel: Single pole relay with changeover contacts

LFD: Single pole relay with changeover contacts

MTL4514B

Channel: Single pole relay

LFD: Single pole relay

Note: reactive loads must be adequately suppressed

Relay characteristics

| | MTL4514/B | MTL5514 |
|-----------------------------|-------------------|--|
| Response time: | 10ms maximum | 10ms maximum |
| Contact rating (Safe Area): | 10W, 0.5A, 35V dc | 250V ac, 2A, $\cos\phi > 0.7$, 40V dc, 2A, resistive load |
| Contact rating (Zone 2): | 10W, 0.5A, 35V dc | 35V, 2A, 100VA. |

MTL4514/B

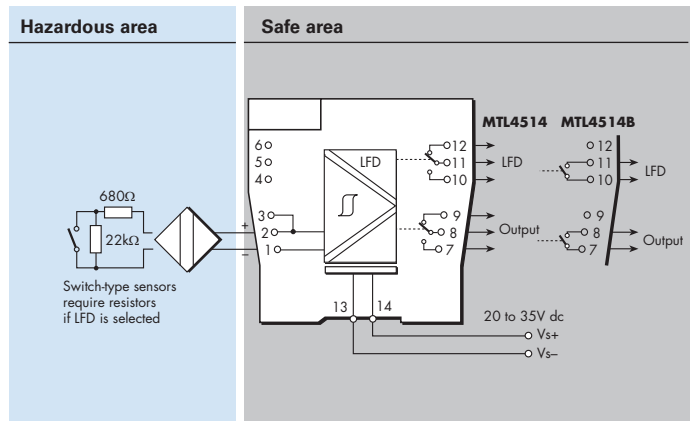

MTL5514

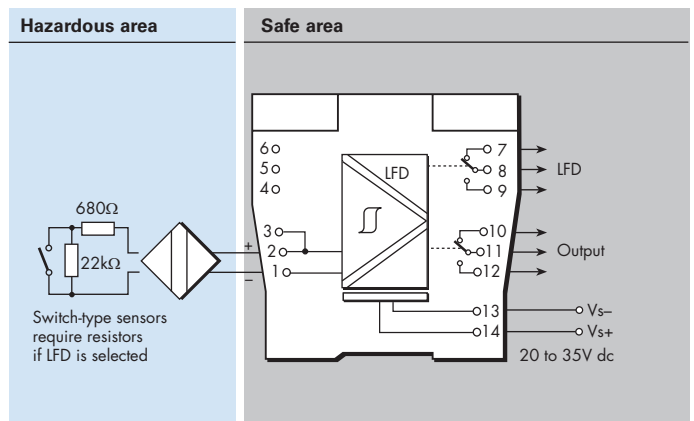

LED indicators

Green: power indication

Yellow: channel status, on when output energised

Red: LFD indication, on when line fault detected

Maximum current consumption

25mA at 24V dc

Power dissipation within unit

0.6W at 24V

Safety description

$U_o=10.5V$ $I_o=14mA$ $P_o=37mW$ $U_m = 253V$ rms or dc



SIL capable

These models have been assessed for use in IEC 61508 functional safety applications.

SIL2 capable for a single device (HFT=0)
SIL3 capable for multiple devices in safety redundant configurations (HFT=1)

See data on MTL web site and refer to the safety manual.

The given data is only intended as a product description and should not be regarded as a legal warranty of properties or guarantee. In the interest of further technical developments, we reserve the right to make design changes.



Powering Business Worldwide

Eaton Electric Limited,

Great Marlings, Butterfield, Luton
Beds, LU2 8DL, UK.
Tel: + 44 (0)1582 723633 Fax: + 44 (0)1582 422283
E-mail: mtlenquiry@eaton.com
www.mtl-inst.com

© 2016 Eaton
All Rights Reserved
Publication No.
EPSx514 Rev7 010916

EUROPE (EMEA):

+44 (0)1582 723633 mtlenquiry@eaton.com

THE AMERICAS:

+1 800 835 7075 mtl-us-info@eaton.com

ASIA-PACIFIC:

+65 6 645 9888 sales.mtlsing@eaton.com

MTL4514D – MTL5514D SWITCH/ PROXIMITY DETECTOR INTERFACE

1-channel, dual output, LFD, phase reversal

The MTLx514D enables two safe-area loads to be controlled, through relays, by a proximity detector or switch located in a hazardous area. When selected, open or short circuit conditions in the field wiring are detected by the line fault detect (LFD) facility and indicated on the top of the module. Switches are provided to select phase reversal and to enable the line fault detection.

SPECIFICATION

See also common specification



Number of channels

One

Location of switch

Zone 0, IIC, T6 hazardous area
Div.1, Group A, hazardous location

Location of proximity detector

Zone 0, IIC, T4–6 hazardous area, if suitably certified
Div.1, Group A, hazardous location

Hazardous-area inputs

Inputs conforming to BS EN60947–5–6:2001 standards for proximity detectors (NAMUR)

Voltage applied to sensor

7 to 9V dc from 1kΩ ±10%

Input/output characteristics

Normal phase

Outputs closed if input > 2.1mA (< 2kΩ in input circuit)

Outputs open if input < 1.2mA (> 10kΩ in input circuit)

Hysteresis: 200µA (650Ω) nominal

Line fault detection (LFD) (when selected)

User-selectable via switches on the side of the unit. Line faults are indicated by an LED. The channel output relays are de-energised if an input line-fault is detected

Open-circuit alarm on if $I_{in} < 50\mu A$

Open-circuit alarm off if $I_{in} > 250\mu A$

Short-circuit alarm on if $R_{in} < 100\Omega$

Short-circuit alarm off if $R_{in} > 360\Omega$

Note: Resistors must be fitted when using the LFD facility with a contact input
500Ω to 1kΩ in series with switch
20kΩ to 25kΩ in parallel with switch

Safe-area output

MTL4514D: two, single pole relays with normally-open contacts

MTL5514D: two, single pole relays with changeover contacts

Note: reactive loads must be adequately suppressed

Relay characteristics

| | MTL4514D | MTL5514D |
|-----------------------------|-------------------|--|
| Response time: | 10ms maximum | 10ms maximum |
| Contact rating (Safe Area): | 10W, 0.5A, 35V dc | 250V ac, 2A, cosØ >0.7, 40V dc, 2A, resistive load |
| Contact rating (Zone 2): | 10W, 0.5A, 35V dc | 35V, 2A, 100VA. |

MTL4514D

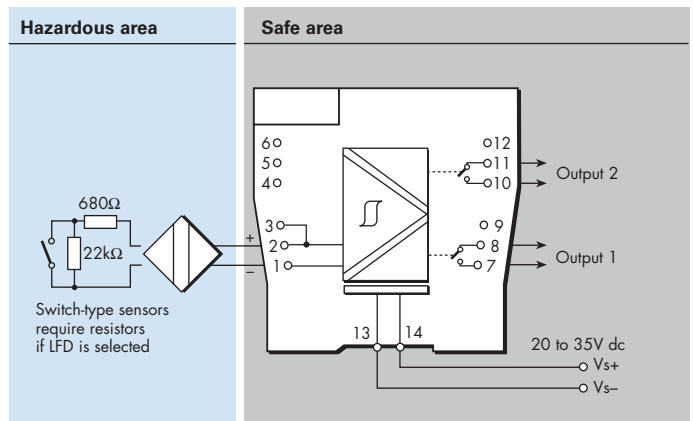

MTL5514D

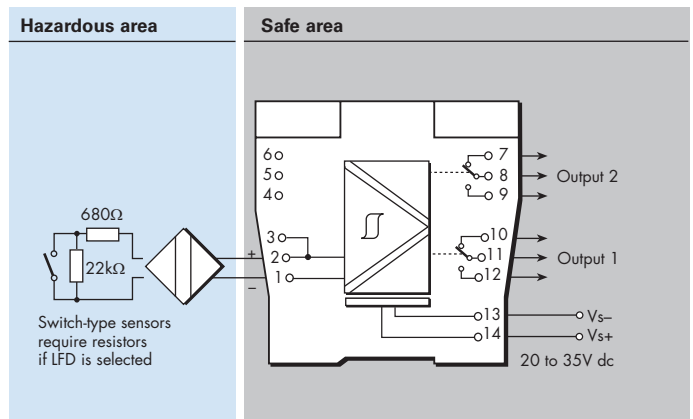

LED indicators

Green: power indication

Yellow: channel status, on when output energised

Red: LFD indication, on when line fault detected

Maximum current consumption

29mA at 24V dc

Power dissipation within unit

0.7W at 24V

Safety description

$U_o=10.5V$ $I_o=14mA$ $P_o=37mW$ $U_m = 253V$ rms or dc



SIL capable

These models have been assessed for use

in IEC 61508 functional safety applications.

SIL2 capable for a single device (HFT=0)

SIL3 capable for multiple devices in safety

redundant configurations (HFT=1)

See data on MTL web site and refer to the safety manual

The given data is only intended as a product description and should not be regarded as a legal warranty of properties or guarantee. In the interest of further technical developments, we reserve the right to make design changes.



Powering Business Worldwide

Eaton Electric Limited,

Great Marlings, Butterfield, Luton
Beds, LU2 8DL, UK.

Tel: + 44 (0)1582 723633 Fax: + 44 (0)1582 422283

E-mail: mtlenquiry@eaton.com

www.mtl-inst.com

© 2016 Eaton
All Rights Reserved
Publication No.
EPSx514D Rev3 010916

EUROPE (EMEA):

+44 (0)1582 723633 mtlenquiry@eaton.com

THE AMERICAS:

+1 800 835 7075 mtl-us-info@eaton.com

ASIA-PACIFIC:

+65 6 645 9888 sales.mtlsing@eaton.com

MTL4514N SWITCH/ PROXIMITY DETECTOR INTERFACE

1-channel, line fault detection, phase reversal

The MTL4514N enables a safe-area load to be controlled, through a relay, by a proximity detector or switch located in a hazardous area. Line faults are signalled through a separate relay and indicated on the top of the module. Switches are provided to select phase reversal and to enable the line fault detection. Resistors, fitted in series with the relay contacts, permit LFD pass-through to the system input.

SPECIFICATION

See also common specification

Number of channels

One

Location of switch

Zone 0, IIC, T6 hazardous area
Div.1, Group A, hazardous location

Location of proximity detector

Zone 0, IIC, T4–6 hazardous area, if suitably certified
Div.1, Group A, hazardous location

Hazardous-area inputs

Inputs conforming to BS EN60947–5–6:2001 standards for proximity detectors (NAMUR)

Voltage applied to sensor

7 to 9V dc from 1k Ω \pm 10%

Input/output characteristics

Normal phase

Outputs closed if input > 2.1mA (< 2k Ω in input circuit)

Outputs open if input < 1.2mA (> 10k Ω in input circuit)

Hysteresis: 200 μ A (650 Ω) nominal

Line fault detection (LFD) (when selected)

User-selectable via switches on the side of the unit. Line faults are indicated by an LED. Line fault relay is de-energised and channel output relay de-energised if input line-fault detected

Open-circuit alarm on if $I_{in} < 50\mu$ A

Open-circuit alarm off if $I_{in} > 250\mu$ A

Short-circuit alarm on if $R_{in} < 100\Omega$

Short-circuit alarm off if $R_{in} > 360\Omega$

Note: Resistors must be fitted when using the LFD facility with a contact input
500 Ω to 1k Ω in series with switch
20k Ω to 25k Ω in parallel with switch

Safe-area output

Channel: Single pole relay in series with 2k2 Ω resistor

LFD: Single pole relay in series with 15k Ω resistor

Note: reactive loads must be adequately suppressed

Relay characteristics

Response time: 10ms maximum

Contact rating: 10W, 0.5A, 35V dc

ID Resistor

18k Ω

MTL4514N

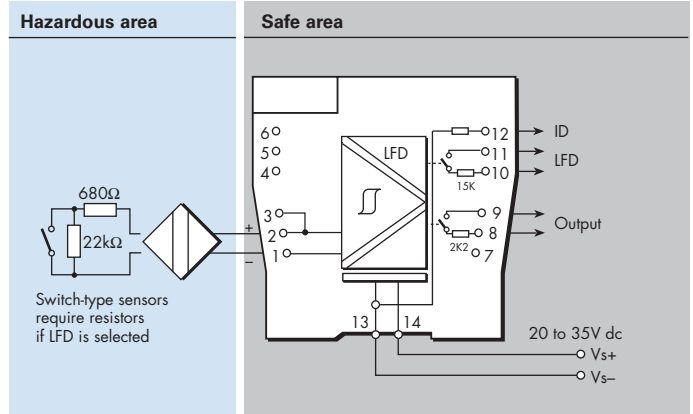

LED indicators

Green: power indication

Yellow: channel status, on when output energised

Red: LFD indication, on when line fault detected

Maximum current consumption

25mA at 24V dc

Power dissipation within unit

0.6W at 24V

Safety description

$U_o=10.5V$ $I_o=14mA$ $P_o=37mW$ $U_m=253V$ rms or dc



SIL capable

These models have been assessed for use in IEC 61508 functional safety applications.

SIL2 capable for a single device (HFT=0)

SIL3 capable for multiple devices in safety redundant configurations (HFT=1)

See data on MTL web site and refer to the safety manual.



Powering Business Worldwide

Eaton Electric Limited,

Great Marlings, Butterfield, Luton
Beds, LU2 8DL, UK.

Tel: + 44 (0)1582 723633 Fax: + 44 (0)1582 422283

E-mail: mtlenquiry@eaton.com

www.mtl-inst.com

© 2016 Eaton

All Rights Reserved

Publication No.

EPS4514N Rev3 010916

EUROPE (EMEA):

+44 (0)1582 723633 mtlenquiry@eaton.com

THE AMERICAS:

+1 800 835 7075 mtl-us-info@eaton.com

ASIA-PACIFIC:

+65 6 645 9888 sales.mtlsing@eaton.com

The given data is only intended as a product description and should not be regarded as a legal warranty of properties or guarantee.

In the interest of further technical developments, we reserve the right to make design changes.

MTL4516/C – MTL5516C SWITCH/ PROXIMITY DETECTOR INTERFACE

2-channel, with line fault detection

The MTLx516/C enable two safe-area loads to be controlled by a switch or proximity detector located in a hazardous-area. When selected, open or short circuit conditions in the field wiring are detected by the line-fault-detect (LFD) facility and also indicated on the top of the module. Phase reversal for each channel is selected by a switch on the side of the module and output is provided by changeover relay contacts.

SPECIFICATION

See also common specification

Number of channels

Two

Location of switches

Zone 0, IIC, T6 hazardous area
Div. 1, Group A hazardous location

Location of proximity detector

Zone 0, IIC, T4–6 hazardous area if suitably certified
Div. 1, Group A hazardous location

Hazardous-area inputs

Inputs conforming to BS EN60947–5–6:2001 standards for proximity detectors (NAMUR)

Voltage applied to sensor

7 to 9V dc from 1k Ω \pm 10%

Input/output characteristics

Normal phase

Outputs closed if input > 2.1mA (< 2k Ω in input circuit)

Outputs open if input < 1.2mA (> 10k Ω in input circuit)

Hysteresis: 200 μ A (650 Ω) nominal

Line fault detection (LFD) (when selected)

User-selectable via switches on the side of the unit. Line faults are indicated by an LED for each channel. The channel output relay is de-energised if an input line fault is detected.

Open-circuit alarm on if $I_{in} < 50\mu$ A

Open-circuit alarm off if $I_{in} > 250\mu$ A

Short-circuit alarm on if $R_{in} < 100\Omega$

Short-circuit alarm off if $R_{in} > 360\Omega$

Note: Resistors must be fitted when using the LFD facility with a contact input
500 Ω to 1k Ω in series with switch
20k Ω to 25k Ω in parallel with switch

Safe-area output

Two single-pole relays with changeover contacts

Note: reactive loads must be adequately suppressed

Relay characteristics

| | MTL4516/C | MTL5516C |
|-----------------------------|-------------------|--|
| Response time: | 10ms maximum | 10ms maximum |
| Contact rating (Safe Area): | 10W, 0.5A, 35V dc | 250V ac, 2A, cos ϕ >0.7, 40V dc, 2A, resistive load |
| Contact rating (Zone 2): | 10W, 0.5A, 35V dc | 35V, 2A, 100VA. |

Maximum current consumption

35mA at 24V

Power dissipation within unit

0.84W at 24V

MTL4516

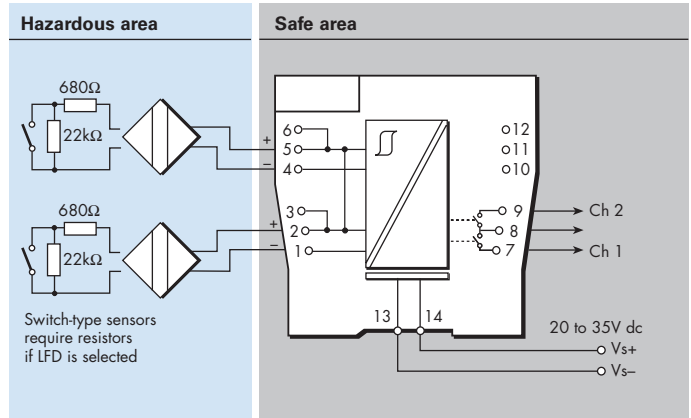

MTL4516C

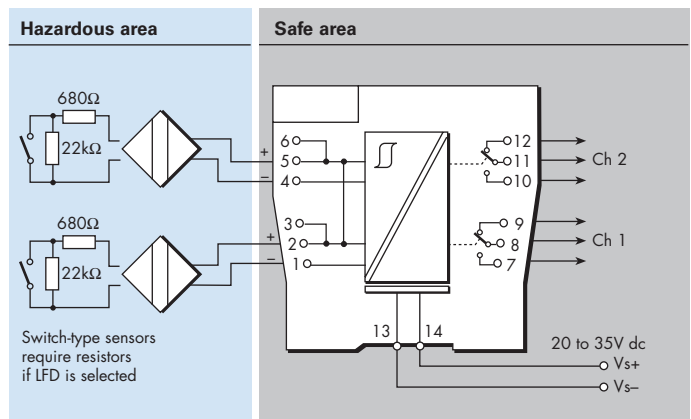

MTL5516C

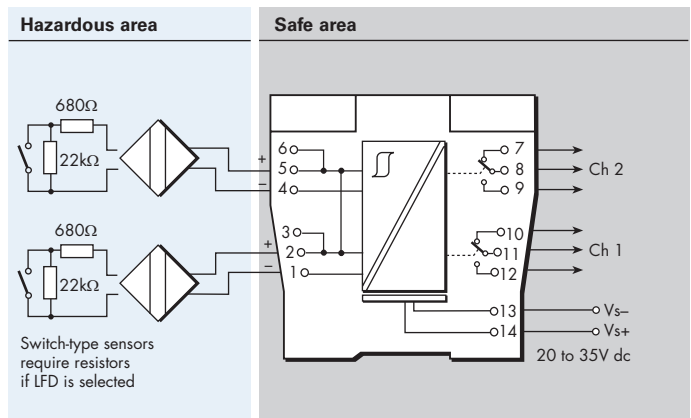

LED indicators

Green: power indication

Yellow: two: channel status, on when output energised

Red: two: LFD indication, on when line fault detected

Safety description (each channel)

$U_o=10.5V$ $I_o=14mA$ $P_o=37mW$ $U_m = 253V$ rms or dc



SIL capable

These models have been assessed for use in IEC 61508 functional safety applications.

SIL2 capable for a single device (HFT=0)

SIL3 capable for multiple devices in safety redundant configurations (HFT=1)

See data on MTL web site and refer to the safety manual

The given data is only intended as a product description and should not be regarded as a legal warranty of properties or guarantee. In the interest of further technical developments, we reserve the right to make design changes.



Powering Business Worldwide

Eaton Electric Limited,

Great Marlings, Butterfield, Luton Beds, LU2 8DL, UK.
Tel: + 44 (0)1582 723633 Fax: + 44 (0)1582 422283
E-mail: mtlenquiry@eaton.com
www.mtl-inst.com

© 2016 Eaton
All Rights Reserved
Publication No.
EPSx516/C Rev6 010916

EUROPE (EMEA):

+44 (0)1582 723633 mtlenquiry@eaton.com

THE AMERICAS:

+1 800 835 7075 mt-us-info@eaton.com

ASIA-PACIFIC:

+65 6 645 9888 sales.mtlsing@eaton.com

MTL4517 – MTL5517 SWITCH/ PROXIMITY DETECTOR INTERFACE

2-channel, line fault detection, phase reversal

The MTLx517 enables two safe-area loads to be controlled, through a relay, by proximity detectors or switches located in a hazardous area. Line faults are signalled through a separate relay and indicated on the top of the module. Switches are provided to select phase reversal and to enable the line fault detection.

SPECIFICATION

See also common specification



Number of channels

Two

Location of switch

Zone 0, IIC, T6 hazardous area
Div.1, Group A, hazardous location

Location of proximity detector

Zone 0, IIC, T4–6 hazardous area, if suitably certified
Div.1, Group A, hazardous location

Hazardous-area inputs

Inputs conforming to BS EN60947–5–6:2001 standards for proximity detectors (NAMUR)

Voltage applied to sensor

7 to 9V dc from $1k\Omega \pm 10\%$

Input/output characteristics

Normal phase

Outputs closed if input $> 2.1mA$ ($< 2k\Omega$ in input circuit)
Outputs open if input $< 1.2mA$ ($> 10k\Omega$ in input circuit)

Hysteresis: $200\mu A$ (650Ω) nominal

Line fault detection (LFD) (when selected)

User selectable by switches on the side of the module.
Line faults are indicated by the LED for each channel.
Line fault relay is energised and channel output relay de-energised if input line-fault detected

Open-circuit alarm on if $I_{in} < 50\mu A$

Open-circuit alarm off if $I_{in} > 250\mu A$

Short-circuit alarm on if $R_{in} < 100\Omega$

Short-circuit alarm off if $R_{in} > 360\Omega$

Note: Resistors must be fitted when using the LFD facility with a contact input
 500Ω to $1k\Omega$ in series with switch
 $20k\Omega$ to $25k\Omega$ in parallel with switch

Safe-area output

Channel: Two single-pole relays with normally open contacts

LFD: Single pole relay with changeover contact (MTL4517)

Single pole relay with normally open contact (MTL5517)

Note: reactive loads must be adequately suppressed

Relay characteristics

| | MTL4517 | MTL5517 |
|-----------------------------|-------------------|--|
| Response time: | 10ms maximum | 10ms maximum |
| Contact rating (Safe Area): | 10W, 0.5A, 35V dc | 250V ac, 2A, $\cos\phi > 0.7$, 40V dc, 2A, resistive load |
| Contact rating (Zone 2): | 10W, 0.5A, 35V dc | 35V, 2A, 100VA. |

MTL4517

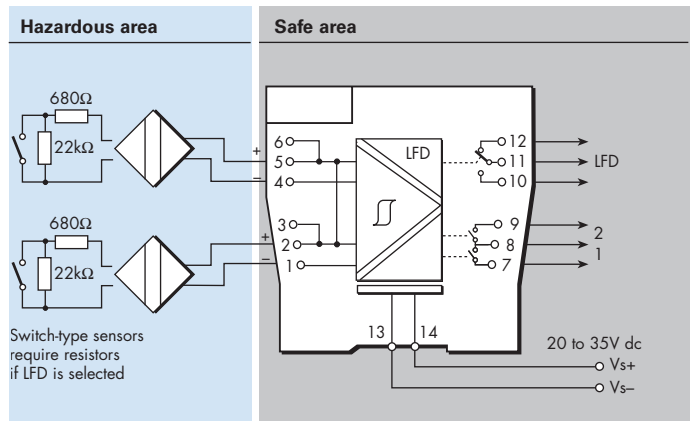

MTL5517

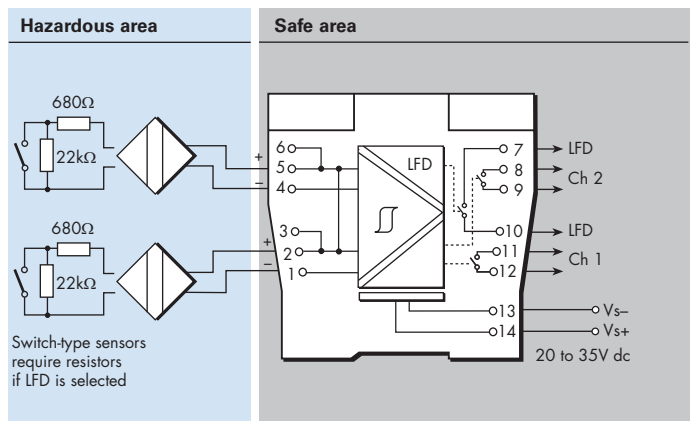

Maximum current consumption

35mA at 24V

Power dissipation within unit

0.84W at 24V

LED indicators

Green: power indication

Yellow: two: channel status, on when output energised

Red: two: LFD indication, on when line fault detected

Safety description (each channel)

$U_o=10.5V$ $I_o=14mA$ $P_o=37mW$ $U_m=253V$ rms or dc



SIL capable

These models have been assessed for use in IEC 61508 functional safety applications.

SIL2 capable for a single device (HFT=0)

SIL3 capable for multiple devices in safety redundant configurations (HFT=1)

See data on MTL web site and refer to the safety manual.

The given data is only intended as a product description and should not be regarded as a legal warranty of properties or guarantee. In the interest of further technical developments, we reserve the right to make design changes.



Powering Business Worldwide

Eaton Electric Limited,

Great Marlings, Butterfield, Luton
Beds, LU2 8DL, UK.
Tel: + 44 (0)1582 723633 Fax: + 44 (0)1582 422283
E-mail: mtlenquiry@eaton.com
www.mtl-inst.com

© 2016 Eaton
All Rights Reserved
Publication No.
EPSx517 Rev6 010916

EUROPE (EMEA):

+44 (0)1582 723633 mtlenquiry@eaton.com

THE AMERICAS:

+1 800 835 7075 mtl-us-info@eaton.com

ASIA-PACIFIC:

+65 6 645 9888 sales.mtlsing@eaton.com

MTL4521/L – MTL5521

SOLENOID/ ALARM DRIVER

loop-powered, IIC

The MTLx521 and the MTL4521L are loop-powered modules which enable a device located in the hazardous area to be controlled from the safe area. They can all drive a certified intrinsically safe low-power load, as well as non-energy-storing simple apparatus such as an LED.

SPECIFICATION

See also common specification



Number of channels

One

Location of load

Zone 0, IIC, T4–6 hazardous area if suitably certified
Div. 1, Group A hazardous location

Minimum output voltage (MTLx521)

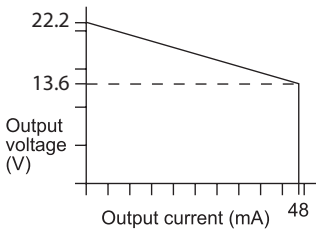

Equivalent output circuit (MTLx521)

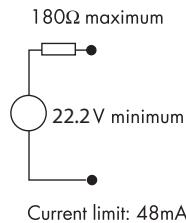

Minimum output voltage (MTL4521L)

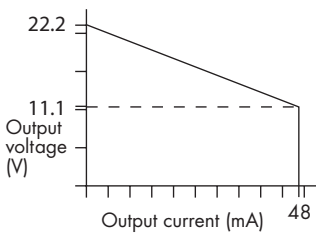

Equivalent output circuit (MTL4521L)

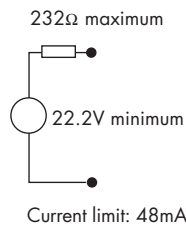

Input voltage

20 to 35V dc

Hazardous-area output (MTLx521)

Minimum output voltage: 13.6V at 48mA
Maximum output voltage: 24V from 180Ω
Current limit: 48mA

Hazardous-area output (MTL4521L)

Minimum output voltage: 11.1V at 48mA
Maximum output voltage: 24V from 232Ω
Current limit: 48mA

Output ripple

< 0.5% of maximum output, peak to peak

Response time

Output within 10% of final value within 100ms

MTL4521 / MTL4521L

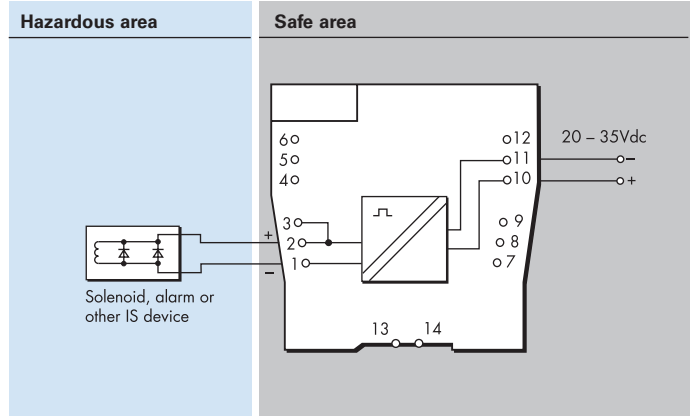

MTL5521

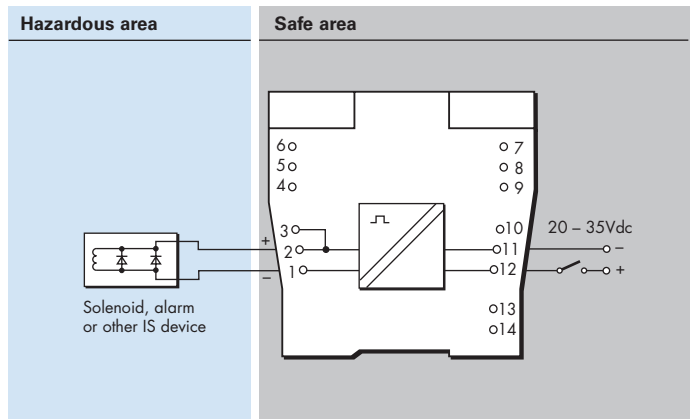

LED indicator

Yellow: output status, on when output active

Maximum current consumption

90mA at 24V

Power dissipation within unit

1.4W at 24V

Safety description (MTLx521)

$U_o=25V$ $I_o=147mA$ $P_o=0.92W$ $U_m=253V$ rms or dc

Safety description (MTL4521L)

$U_o=25V$ $I_o=108mA$ $P_o=0.68W$ $U_m=253V$ rms or dc



SIL capable

These models have been assessed for use in IEC 61508 functional safety applications.

SIL3 capable for a single device (HFT=0) when the required function is to de-energise the output.

SIL1 capable for a single device (HFT=0) when the required function is to energise the output.

See data on MTL web site and refer to the safety manual.



Powering Business Worldwide

Eaton Electric Limited,

Great Marlings, Butterfield, Luton
Beds, LU2 8DL, UK.
Tel: +44 (0)1582 723633 Fax: +44 (0)1582 422283
E-mail: mtlenquiry@eaton.com
www.mtl-inst.com

© 2016 Eaton
All Rights Reserved
Publication No.
EPSx521 Rev7 010916

EUROPE (EMEA):

+44 (0)1582 723633 mtlenquiry@eaton.com

THE AMERICAS:

+1 800 835 7075 mtl-us-info@eaton.com

ASIA-PACIFIC:

+65 6 645 9888 sales.mtlsing@eaton.com

The given data is only intended as a product description and should not be regarded as a legal warranty of properties or guarantee.
In the interest of further technical developments, we reserve the right to make design changes.

MTL5522

SOLENOID/ALARM DRIVER

loop-powered, IIB

The MTL5522 is a loop-powered module which enables a device located in the hazardous area to be controlled from the safe area. The MTL5522 can drive a certified intrinsically safe low-power load, as well as non-energy-storing simple apparatus such as an LED. The unit's input/output isolation allows the control switch to be connected into either side of the 24V dc supply circuit.

SPECIFICATION

See also common specification

Number of channels

One

Location of load

Zone 0, IIB, T4-6 hazardous area if suitably certified
Div. 1, Group C hazardous location

Minimum output voltage

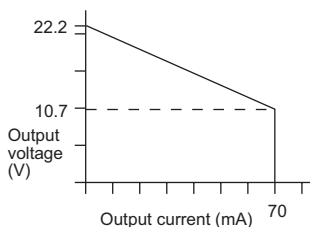

Equivalent output circuit

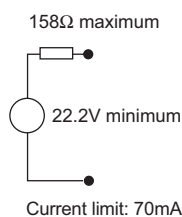

Input voltage

20 to 35V dc

Hazardous-area output

Minimum output voltage: 10.7V at 70mA
Maximum output voltage: 24V from 158Ω
Current limit: 70mA

Output ripple

< 0.5% of maximum output, peak to peak

Response time

Output within 10% of final value within 100ms



MTL5522

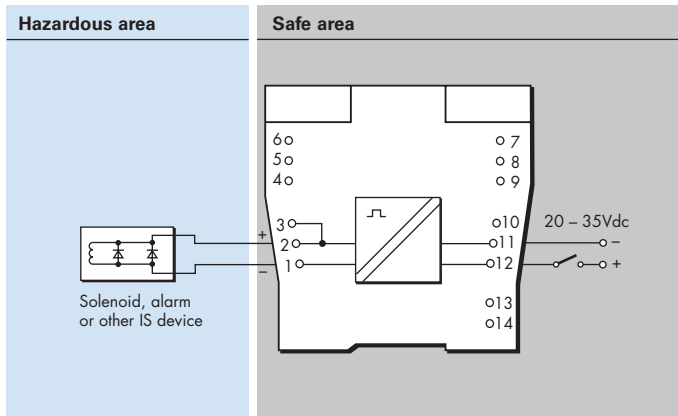

LED indicator

Yellow: output status, on when output active

Maximum current consumption

125mA (typ.) at 24V

Power dissipation within unit

1.4W at 24V

Safety description

$U_o=25V$ $I_o=166mA$ $P_o=1.04W$ $U_m=253V$ rms or dc



SIL capable

These models have been assessed for use in IEC 61508 functional safety applications. SIL3 capable for a single device (HFT=0) when the required function is to de-energise the output.

SIL1 capable for a single device (HFT=0) when the required function is to energise the output.

See data on MTL web site and refer to the safety manual.



Powering Business Worldwide

Eaton Electric Limited,

Great Marlings, Butterfield, Luton
Beds, LU2 8DL, UK.
Tel: + 44 (0)1582 723633 Fax: + 44 (0)1582 422283
E-mail: mtlenquiry@eaton.com
www.mtl-inst.com

© 2016 Eaton
All Rights Reserved
Publication No.
EPSx522 Rev7 010916

EUROPE (EMEA):

+44 (0)1582 723633 mtlenquiry@eaton.com

THE AMERICAS:

+1 800 835 7075 mtl-us-info@eaton.com

ASIA-PACIFIC:

+65 6 645 9888 sales.mtlsing@eaton.com

The given data is only intended as a product description and should not be regarded as a legal warranty of properties or guarantee.

In the interest of further technical developments, we reserve the right to make design changes.

MTL4523/R – MTL5523

SOLENOID/ALARM DRIVER

with line fault detection, IIC

With the MTLx523 interface, an on/off device in a hazardous area can be controlled by a volt-free contact or logic signal in the safe area. It is suitable for driving loads such as solenoids. Line fault detection (LFD), which operates irrespective of the output state, is signalled by a safe-area solid-state switch which de-energises MTLx523, or energises MTL4523R, if a field line is open or short-circuited. Earth fault detection can be provided by connecting an MTL4220 earth leakage detector to terminal 3.

SPECIFICATION

See also common specification



Number of channels

One

Location of load

Zone 0, IIC, T4–6 hazardous area if suitably certified
Div. 1, Group A, hazardous location

Minimum output voltage

Equivalent output circuit

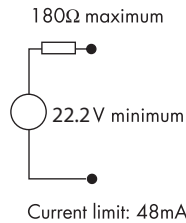
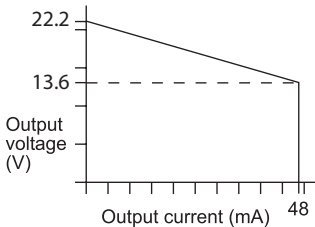

Hazardous-area output

Minimum output voltage: 13.6V at 48mA
Maximum output voltage: 24V from 180Ω
Maximum off-state output voltage: 4V from 180Ω
Current limit: 48mA

Output ripple

< 0.5% of maximum output, peak to peak

Control input

Suitable for switch contacts, an open collector transistor or logic drive. (Internal contact wetting voltage 12V @ 0.2mA contact closed. Not suitable for voltage control via series diode.)
Output turns on if input switch closed, transistor on or < 1.4V applied across control input
Output turns off if input switch open, transistor off or > 4.5V applied across control input

Response time

Output within 10% of final value within 100ms

Line fault detection (LFD)

Open or short circuit in field cabling de-energises* solid state line-fault signal.
LFD transistor is switched on*, provided that the field circuit impedance is > 55Ω and < 4kΩ.

* These conditions are reversed for the MTL4523R. This is to permit parallel connection of alarms between modules to provide a group alarm output.

MTL4523 / MTL4523R

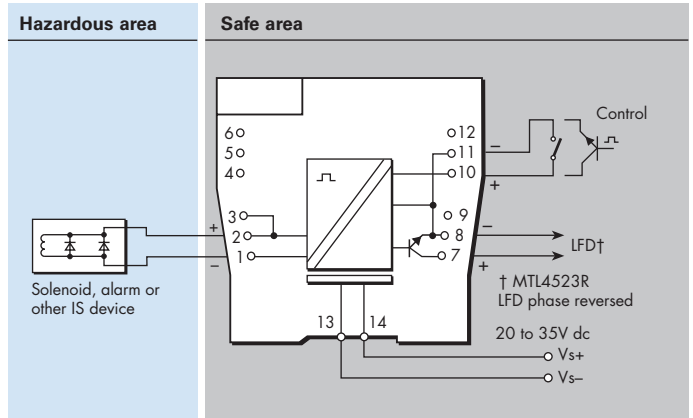

MTL5523

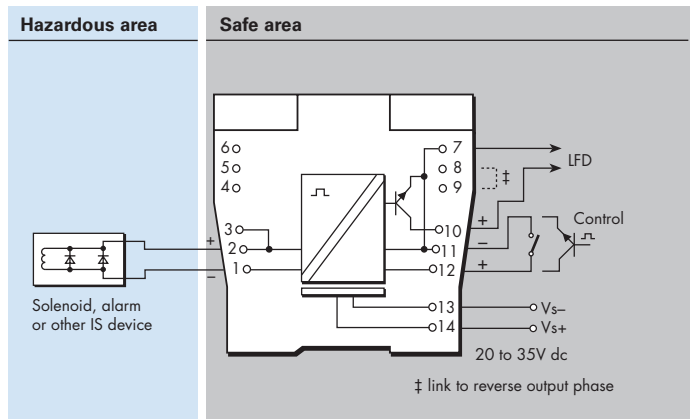

Line fault signal characteristics

Maximum off-state voltage: 35V
Maximum off-state leakage current: 10μA
Maximum on-state voltage drop: 2V
Maximum on-state current: 50mA

LED indicators

Green: power indication
Yellow: output status, on when output active
Red: LFD indication, on when line fault detected

Maximum current consumption

100mA at 24V dc

Power dissipation within unit

1.2W with typical solenoid valve, output on
2.0W worst case

Safety description

$U_o=25V$ $I_o=147mA$ $P_o=0.92W$ $U_m=253V$ rms or dc



SIL capable

These models have been assessed for use in IEC 61508 functional safety applications.
SIL2 capable for a single device (HFT=0)
SIL3 capable for multiple devices in safety redundant configurations (HFT=1)
See data on MTL web site and refer to the safety manual.

MTL4523L

SOLENOID/ ALARM DRIVER

loop-powered with line fault detection, IIC

With the MTL4523L interface, an on/off device in a hazardous area can be controlled by a voltage signal in the safe area. It is suitable for driving loads such as solenoids. Line fault detection (LFD), which operates when the output is energised, is signalled by a safe-area solid-state switch which energises if a field line is open or short-circuited. Earth fault detection can be provided by connecting an MTL4220 earth leakage detector to terminal 3.

SPECIFICATION

See also common specification

Number of channels

One

Location of load

Zone 0, IIC, T4–6 hazardous area if suitably certified
Div. 1, Group A, hazardous location

Minimum output voltage Equivalent output circuit

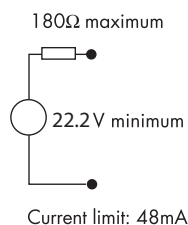
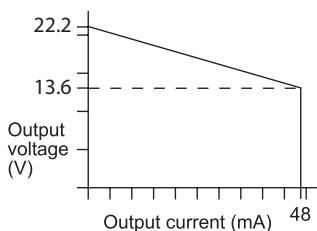

Input voltage

20 to 35V dc

Hazardous-area output

Minimum output voltage: 13.6V at 48mA
Maximum output voltage: 24V from 180Ω
Current limit: 48mA

Output ripple

< 0.5% of maximum output, peak to peak

Response time

Output within 10% of final value within 100ms

Line fault detection (LFD)

Open or short circuit in field cabling energises solid state line fault signal

LFD transistor is switched on, provided that the field circuit impedance is > 55Ω and < 4kΩ.

Line fault signal characteristics

Maximum off-state voltage: 35V
Maximum off-state leakage current: 10μA
Maximum on-state voltage drop: 2V
Maximum on-state current: 50mA
Note: LFD signal is Zener-diode protected against inductive loads

MTL4523L

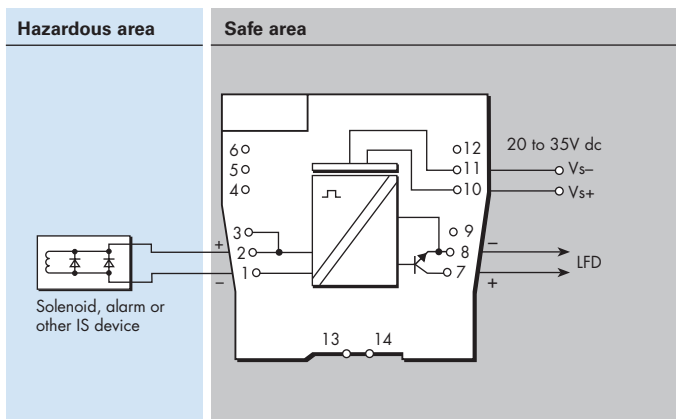

LED indicators

Yellow: output status, on when output active

Red: LFD indication, on when line fault detected

Maximum current consumption

100mA at 24V dc

Power dissipation within unit

1.2W with typical solenoid valve, output on

Safety description

$U_o=25V$ $I_o=147mA$ $P_o=0.92W$ $U_m=253V$ rms or dc



SIL capable

These models have been assessed for use in IEC 61508 functional safety applications. SIL3 capable for a single device (HFT=0) when the required function is to de-energise the output.

SIL1 capable for a single device (HFT=0) when the required function is to energise the output.

See data on MTL web site and refer to the safety manual.



Powering Business Worldwide

Eaton Electric Limited,

Great Marlings, Butterfield, Luton
Beds, LU2 8DL, UK.
Tel: + 44 (0)1582 723633 Fax: + 44 (0)1582 422283
E-mail: mtlenquiry@eaton.com
www.mtl-inst.com

© 2016 Eaton
All Rights Reserved
Publication No.
EPS4523L Rev9 010916

EUROPE (EMEA):

+44 (0)1582 723633 mtlenquiry@eaton.com

THE AMERICAS:

+1 800 835 7075 mt-us-info@eaton.com

ASIA-PACIFIC:

+65 6 645 9888 sales.mtlsing@eaton.com

The given data is only intended as a product description and should not be regarded as a legal warranty of properties or guarantee.
In the interest of further technical developments, we reserve the right to make design changes.

MTL4523V/VL – MTL5523V/VL SOLENOID/ALARM DRIVER with line fault detection, IIC

With the MTLx523V/VL interface, an on/off device in a hazardous area can be controlled by a voltage signal in the safe area. It is suitable for driving loads such as solenoids. Line fault detection (LFD), which operates irrespective of the output state, is signalled by a safe-area solid-state switch which energises if a field line is open or short-circuited. Earth fault detection can be provided by connecting an MTL4220 earth leakage detector to terminal 3.

SPECIFICATION

See also common specification



Number of channels

One

Location of load

Zone 0, IIC, T4–6 hazardous area if suitably certified
Div. 1, Group A, hazardous location

Minimum output voltage Equivalent output circuit (MTLx523V)

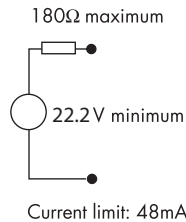
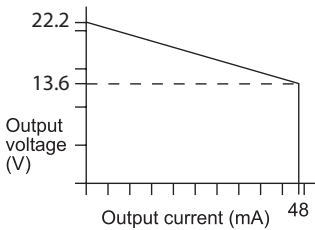

Minimum output voltage Equivalent output circuit (MTLx523VL)

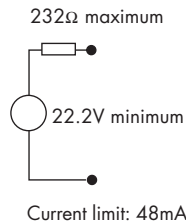
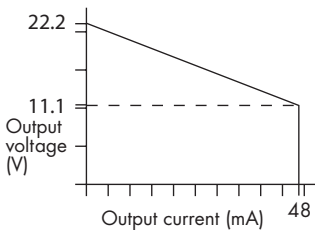

Hazardous-area output (MTLx523V)

Minimum output voltage: 13.6V at 48mA
Maximum output voltage: 24V from 180Ω
Maximum off-state output voltage: 4V from 180Ω
Current limit: 48mA

Hazardous-area output (MTLx523VL)

Minimum output voltage: 11.1V at 48mA
Maximum output voltage: 24V from 232Ω
Maximum off-state output voltage: 4V from 232Ω
Current limit: 48mA

Output ripple

< 0.5% of maximum output, peak to peak

Control input

Suitable for 24V logic drive
Output turns on if > 18V applied across control input
Output turns off if < 5V applied across control input
Maximum control input voltage: 28V
Maximum control system output leakage current: 0.5mA

Response time

Output within 10% of final value within 100ms

MTL4523V/MTL4523VL

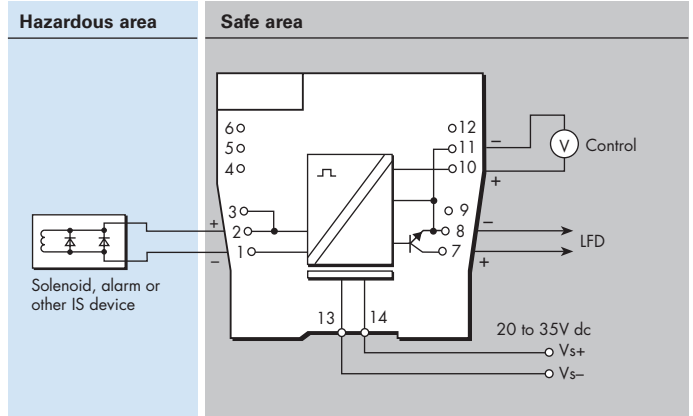

MTL5523V/MTL5523VL

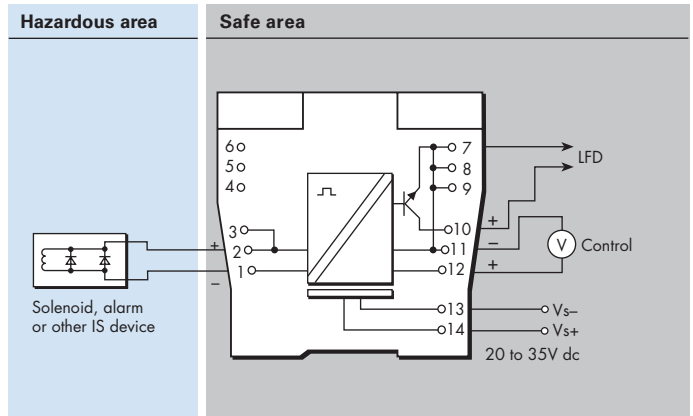

Line fault detection (LFD)

Open or short circuit in field cabling energises solid state line-fault signal.

LFD transistor is switched off, provided that the field circuit impedance is > 55Ω and < 4kΩ.

Line fault signal characteristics

Maximum off-state voltage: 35V
Maximum off-state leakage current: 10μA
Maximum on-state voltage drop: 2V
Maximum on-state current: 50mA

LED indicators

Green: power indication
Yellow: output status, on when output active
Red: LFD indication, on when line fault detected

Maximum current consumption

100mA at 24V dc

Power dissipation within unit

1.2W with typical solenoid valve, output on
2.0W worst case

Safety description (MTLx523V)

$V_o=25V$ $I_o=147mA$ $P_o=0.92W$ $U_m=253V$ rms or dc

Safety description (MTLx523VL)

$V_o=25V$ $I_o=108mA$ $P_o=0.68W$ $U_m=253V$ rms or dc



SIL capable

These models have been assessed for use in IEC 61508 functional safety applications.
SIL2 capable for a single device (HFT=0)
SIL3 capable for multiple devices in safety redundant configurations (HFT=1)
See data on MTL web site and refer to the safety manual.

The given data is only intended as a product description and should not be regarded as a legal warranty of properties or guarantee.
In the interest of further technical developments, we reserve the right to make design changes.

MTL4524 – MTL5524

SOLENOID/ALARM DRIVER

switch operated with override, IIC

The MTLx524 enables an on/off device in a hazardous area to be controlled by a volt-free contact or logic signal in the safe area. It can drive loads such as solenoids, alarms, LEDs and other low power devices that are certified as intrinsically safe or are classified as non-energy storing simple apparatus.

The MTL4524 allows a second safe-area switch or logic signal to be connected enabling the output to be disabled to permit, for example, a safety system to override a control signal.

The MTL5524 has its phase reversed by connecting a wire link between pins 8 and 9.

SPECIFICATION

See also common specification

Number of channels

One

Location of load

Zone 0, IIC, T4–6 hazardous area if suitably certified
Div.1, Group A, hazardous location

Minimum output voltage Equivalent output circuit

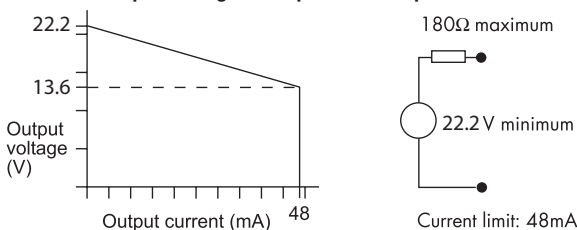

Hazardous-area output

Minimum output voltage: 13.6V at 48mA
Maximum output voltage: 24V from 180Ω
Maximum off-state output voltage: 4V from 180Ω
Current limit: 48mA

Output ripple

< 0.5% of maximum output, peak-to-peak

Control input

Suitable for switch contacts, an open collector transistor or logic drive
0 = input switch closed, transistor on or <1.4V applied
1 = input switch open, transistor off or >4.5V applied

Override input on MTL4524

An open collector transistor or a switch connected across the terminals can be used to turn the output off whatever the state of the control input
0 = transistor on or switch closed
1 = transistor off or switch open

Control and override inputs on MTL4524

| Control input | Override input | Output state |
|---------------|----------------|--------------|
| 0 | 0 | off |
| 0 | 1 | on |
| 1 | 0 | off |
| 1 | 1 | off |

Response time

Output within 10% of final value within 100ms



MTL4524

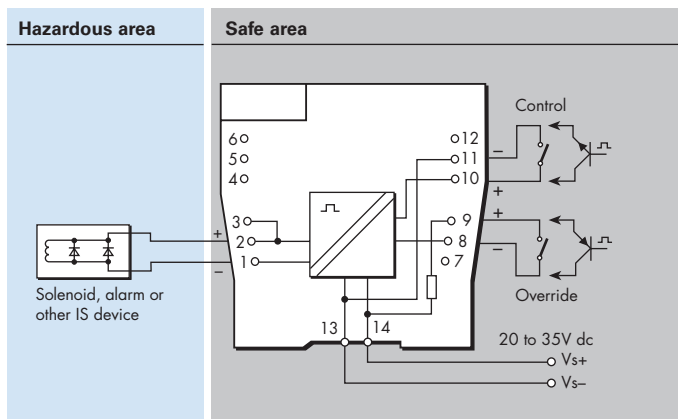

MTL5524

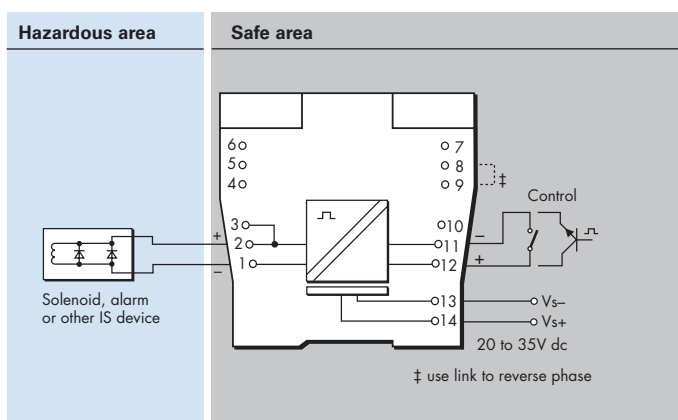

LED indicators

Green: power indication
Yellow: output status, on when output active

Maximum current consumption

100mA at 24V dc

Power dissipation within unit

1.3W with typical solenoid valve, output on
1.9W worst case

Safety description

$U_o=25V$ $I_o=147mA$ $P_o=0.92W$ $U_m=253V$ rms or dc



SIL capable

These models have been assessed for use in IEC 61508 functional safety applications. SIL2 capable for a single device (HFT=0) SIL3 capable for multiple devices in safety redundant configurations (HFT=1) See data on MTL web site and refer to the safety manual.

MTL4524S

SOLENOID/ALARM DRIVER

switch operated with 24V override, IIC

The MTL4524S enables an on/off device in a hazardous area to be controlled by a volt-free contact or a floating logic signal in the safe area. It can drive loads such as solenoids, alarms, LEDs and other low power devices that are certified as intrinsically safe or are classified as non-energy storing simple apparatus. By connecting a second safe-area voltage, the output can be disabled to permit, for example, a safety system to override a control signal.

SPECIFICATION

See also common specification

Number of channels

One

Location of load

Zone 0, IIC, T4–6 hazardous area if suitably certified
Div.1, Group A, hazardous location

Minimum output voltage Equivalent output circuit

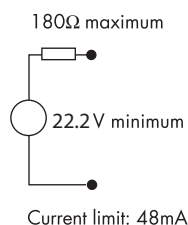
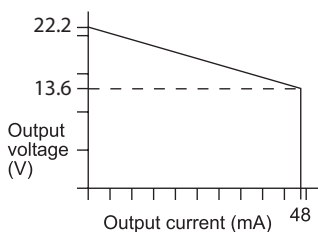

Hazardous-area output

Minimum output voltage: 13.6V at 48mA
Maximum output voltage: 24V from 180Ω
Maximum off-state output voltage: 4V from 180Ω
Current limit: 48mA

Output ripple

< 0.5% of maximum output, peak-to-peak

Control input (must be fully-floating)

Suitable for switch contacts or an opto-isolator
0 = input switch closed, transistor on or < 1.4V applied
1 = input switch open, transistor off or > 4.5V applied

Override input

A 24V logic signal applied across the terminals allows the solenoid/ alarm to be operated by the control input. If it is disconnected, the solenoid/alarm is off.
0 = < 2.0V applied across terminals 8 & 9
1 = > 9.0V applied across terminals 8 & 9
(nominal switching point 4.5V)

Control and override inputs

| Control input | Override input | Output state |
|---------------|----------------|--------------|
| 0 | 0 | off |
| 0 | 1 | on |
| 1 | 0 | off |
| 1 | 1 | off |

Response time

Output within 10% of final value within 100ms

MTL4524S

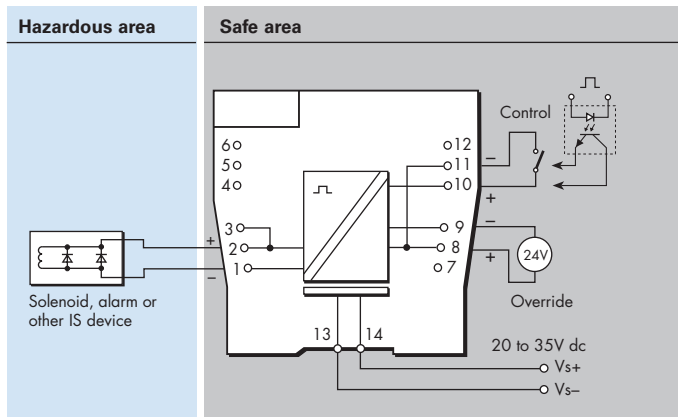

LED indicators

Green: power indication
Yellow: output status, on when output active

Maximum current consumption

100mA at 24V dc

Power dissipation within unit

1.3W with typical solenoid valve, output on
1.9W worst case

Safety description

$U_o=25V$ $I_o=147mA$ $P_o=0.92W$ $U_m=253V$ rms or dc



SIL capable

These models have been assessed for use in IEC 61508 functional safety applications. SIL2 capable for a single device (HFT=0) SIL3 capable for multiple devices in safety redundant configurations (HFT=1) See data on MTL web site and refer to the safety manual.

MTL4525 – MTL5525

SOLENOID/ALARM DRIVER

switch operated with override, IIC, low power

The MTLx525 enables an on/off device in a hazardous area to be controlled by a volt-free contact or logic signal in the safe area. It can drive loads such as solenoids, alarms, LEDs and other low power devices that are certified as intrinsically safe or are classified as non-energy storing simple apparatus.

The MTL4525 allows a second safe-area switch or logic signal to be connected that enables the output to be disabled to permit, for example, a safety system to override a control signal.

SPECIFICATION

See also common specification



Number of channels

One

Location of load

Zone 0, IIC, T4–6 hazardous area if suitably certified
Div.1, Group A, hazardous location

Minimum output voltage Equivalent output circuit

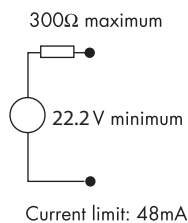
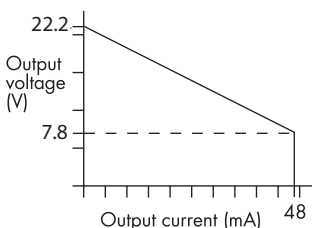

Hazardous-area output

Minimum output voltage: 7.8V at 48mA
Maximum output voltage: 24V from 300Ω
Maximum off-state output voltage: 4V from 300Ω
Current limit: 48mA

Output ripple

< 0.5% of maximum output, peak-to-peak

Control input on MTL4525

Suitable for switch contacts, an open collector transistor or logic drive

0 = input switch closed, transistor on or < 1.4V applied

1 = input switch open, transistor off or > 4.5V applied

Override input on MTL4525

An open collector transistor or a switch connected across the terminals can be used to turn the output off whatever the state of the control input

0 = transistor on or switch closed

1 = transistor off or switch open

Control and override inputs on MTL4525

| Control input | Override input | Output state |
|---------------|----------------|--------------|
| 0 | 0 | off |
| 0 | 1 | on |
| 1 | 0 | off |
| 1 | 1 | off |

Response time

Output within 10% of final value within 100ms

MTL4525

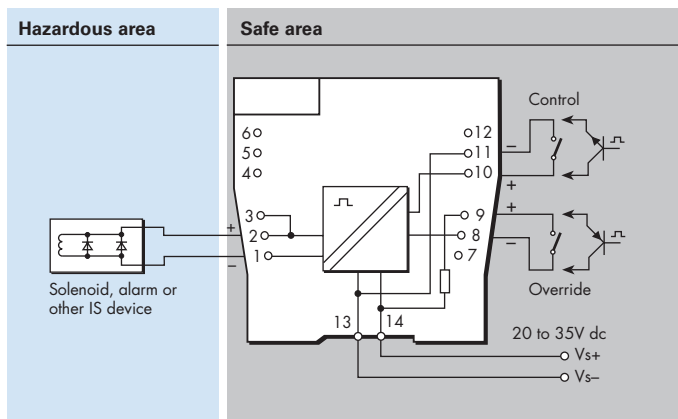

MTL5525

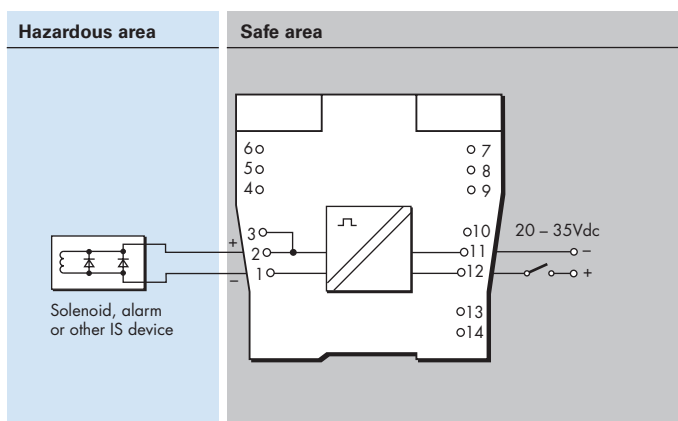

LED indicators

Green: power indication

Yellow: output status, on when output active

Maximum current consumption

100mA at 24V dc

Power dissipation within unit

1.3W with typical solenoid valve, output on
1.9W worst case

Safety description

$U_o=25V$ $I_o=83.3mA$ $P_o=0.52W$ $U_m = 253V$ rms or dc



SIL capable

These models have been assessed for use in IEC 61508 functional safety applications.

SIL2 (SIL3 for MTL5525) capable for a single device (HFT=0)

SIL3 capable for multiple devices in safety redundant configurations (HFT=1)

See data on MTL web site and refer to the safety manual.

MTL4526 – MTL5526

SWITCH-OPERATED RELAY

2-channel IS-output

The MTLx526 enables two separate IS circuits in a hazardous area to be contact controlled by one or two, on/off, control signals in a safe area. Applications include the calibration of strain-gauge bridges; changing the polarity (and thereby the tone) of an IS sounder; the testing of IS fire alarms; and the transfer of safe-area signals into an annunciator with IS input terminals not segregated from each other. The output-relay contacts are certified as non-energy-storing apparatus, and can be connected to any IS circuit without further certification, provided that separate IS circuits are such that they would remain safe if connected together.

SPECIFICATION

See also common specification

Number of channels

Two, fully floating

Location of control circuit

Safe area

Input/output characteristics

Contact/Logic mode

(Inputs suitable for switch contacts, an open-collector transistor or logic drive)

Relay energised if < 450Ω or < 1V applied

Relay de-energised if > 5kΩ or > 2V applied (35V max.)

Loop powered mode

Relay energised if > 20V

Relay de-energised if < 17V

Power supply failure protection

Relays de-energised if supply fails

Response time

25ms nominal

Contacts (suitable for connection to IS circuits)

1-pole changeover per channel

Contact rating

250V ac, limited to 40V dc for IS applications, 2A (reactive loads must be suppressed)

Contact life expectancy

2 x 10⁷ operations at maximum IS load

Relay drive (see switch setting table)

Choice of "loop-powered" or "contact/logic" control, for both channels, by switch selection. A further switch option ("1in2out") enables either input, in contact/logic mode, to activate both outputs.

MTL4526

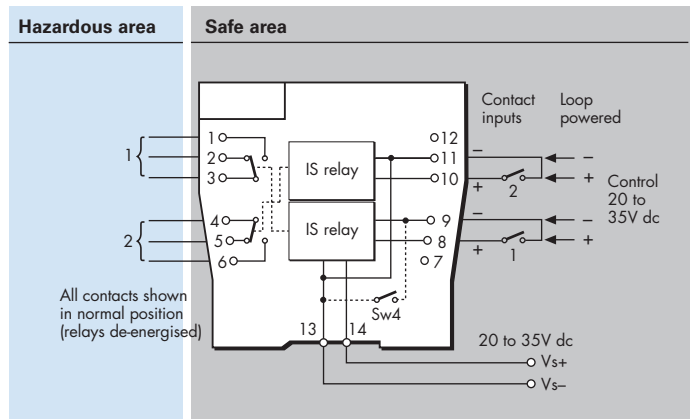

MTL5526

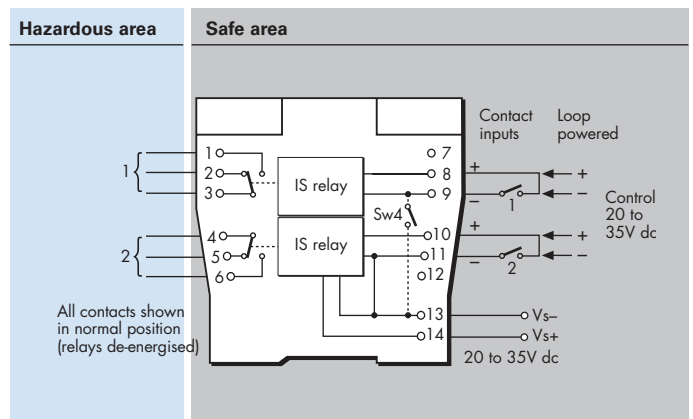

LED indicators

Green: power indication

Yellow: two: output status, on when relay energised

Power requirement, Vs

41mA at 20V dc

44mA at 24V dc

60mA at 35V dc

Power dissipation within unit

1.1W maximum at 24V

Safety description (each channel)

Non-energy-storing apparatus: relay contacts may be connected to any IS circuit without further consideration

User switch settings for operating mode

| Mode | Function | SW1 | SW2 | SW3 | SW4 |
|---------------------|----------|-----|-----|-----|-----|
| Contact/Logic Input | 2 ch | Off | On | On | On |
| | 1in2out | On | On | On | On |
| Loop Powered | 2 ch | Off | Off | Off | Off |



Powering Business Worldwide

Eaton Electric Limited,

Great Marlings, Butterfield, Luton Beds, LU2 8DL, UK.
Tel: + 44 (0)1582 723633 Fax: + 44 (0)1582 422283
E-mail: mtlenquiry@eaton.com
www.mtl-inst.com

© 2016 Eaton
All Rights Reserved
Publication No.
EPSx526 Rev7 010916

EUROPE (EMEA):

+44 (0)1582 723633 mtlenquiry@eaton.com

THE AMERICAS:

+1 800 835 7075 mtl-us-info@eaton.com

ASIA-PACIFIC:

+65 6 645 9888 sales.mtlsing@eaton.com

The given data is only intended as a product description and should not be regarded as a legal warranty of properties or guarantee. In the interest of further technical developments, we reserve the right to make design changes.

MTL4531 – MTL5531 VIBRATION TRANSDUCER INTERFACE

The MTLx531 repeats a signal from a vibration sensor in a hazardous area, providing an output for a monitoring system in the safe area. The interface is compatible with 3-wire eddy-current probes and accelerometers or 2-wire current sensors; the selection is made by a switch on the side of the module.

SPECIFICATION

See also common specification

Number of channels

One

Sensor type

2- or 3-wire vibration transducer

Location of signal source

Zone 0, IIC, T4–6 hazardous area if suitably certified
Div. 1, Group A hazardous location

Hazardous-area input

Input impedance
(terminals 2 & 3): 10k Ω

Transducer supply voltage, 3-wire (terminals 3 & 1)

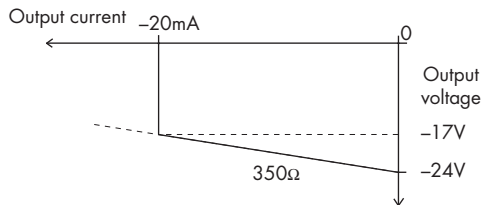

Transducer supply current, 2-wire

3.3mA (nom.) for 2-wire sensors, user selectable by switch

Signal range

Minimum -20V, maximum -0.5V

DC transfer accuracy at 20°C

< \pm 50mV

AC transfer accuracy at 20°C

0Hz to 1kHz: \pm 1%
1kHz to 10kHz: -5% to +1%
10kHz to 20kHz: -10% to +1%

Temperature coefficient

\pm 50ppm/ $^{\circ}$ C (10 to 65 $^{\circ}$ C)
 \pm 100ppm/ $^{\circ}$ C (-20 to 10 $^{\circ}$ C)

Voltage bandwidth

-3dB at 47kHz (typical)

Phase response

<14 μ s, equivalent to:
-1 $^{\circ}$ at 200Hz
-3 $^{\circ}$ at 600Hz
-5 $^{\circ}$ at 1kHz
-50 $^{\circ}$ at 10kHz
-100 $^{\circ}$ at 20kHz

Safe-area output impedance

<20 Ω

LED indicator

Green: power indication



MTL4531

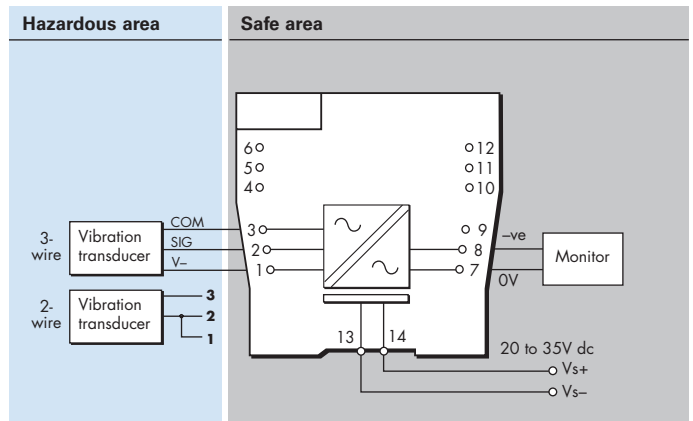

MTL5531

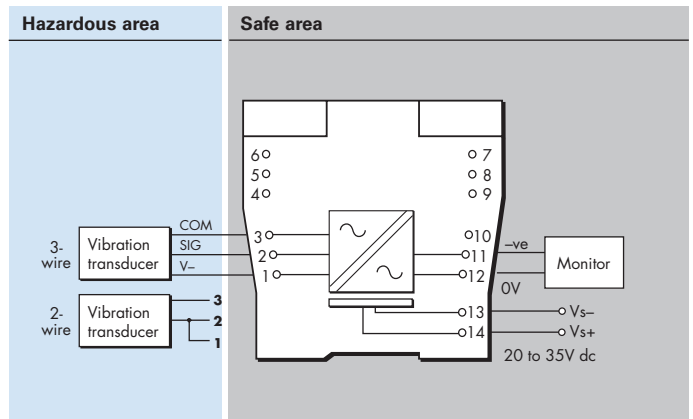

Supply voltage

20 to 35V dc

Maximum current consumption (10mA transducer load)

96mA at 24V

Maximum power dissipation within unit

2W

Safety description

Terminals 3 to 1

$U_o=26.6V$ $I_o=94mA$ $P_o=0.66W$ $U_m=253V$ rms or dc

Terminals 3 to 2

Non-energy-storing apparatus $\leq 1.5V$, $\leq 0.1A$ and $\leq 25mW$

Note -

Refer to the Instruction Manual for recommendations on mounting of these modules.

Due to the high power dissipation the maximum ambient temperature for these modules when mounted in horizontal orientation is:

- close packed 45 $^{\circ}$ C
- minimum of 10mm spacing 55 $^{\circ}$ C



SIL capable

These models have been assessed for use in IEC 61508 functional safety applications.

SIL1 capable for a single device (HFT=0)

SIL2 capable for multiple devices in safety redundant configuration (HFT=1)

See data on MTL web site and refer to the safety manual.

The given data is only intended as a product description and should not be regarded as a legal warranty of properties or guarantee. In the interest of further technical developments, we reserve the right to make design changes.



Powering Business Worldwide

Eaton Electric Limited,

Great Marlings, Butterfield, Luton
Beds, LU2 8DL, UK.
Tel: + 44 (0)1582 723633 Fax: + 44 (0)1582 422283
E-mail: mtlenquiry@eaton.com
www.mtl-inst.com

© 2016 Eaton
All Rights Reserved
Publication No.
EPSx531 Rev6 010916

EUROPE (EMEA):

+44 (0)1582 723633 mtlenquiry@eaton.com

THE AMERICAS:

+1 800 835 7075 mtl-us-info@eaton.com

ASIA-PACIFIC:

+65 6 645 9888 sales.mtlsing@eaton.com

MTL4532 – MTL5532

PULSE ISOLATOR

pulse & 4/20mA current outputs

The MTLx532 isolates pulses from a switch, proximity detector, current pulse transmitter or voltage pulse transmitter located in a hazardous area. It is ideal for applications involving high pulse rates and fast response times, by repeating the pulses into the safe area. An analogue output proportional to frequency is also provided, together with a relay output, which may be configured to act as an alarm. Configuration is carried out with a personal computer.

SPECIFICATION

See also common specification

Number of channels

One, fully floating

Sensor type

Switch or proximity detector (NAMUR/BS EN 60947-5-6:2001)
2- or 3-wire voltage or pulse transmitter

Location of switch

Zone 0, IIC, T6 hazardous area
Div. 1, Group A, hazardous location

Location of proximity detector or transmitter

Zone 0, IIC, T4-T6 if suitably certified
Div.1, Group A, hazardous location

Input

Switch input:
Output ON if switch is closed
Proximity detector input:
Excitation: 7.0 to 9.0V dc from 1k Ω nominal
Output ON if input > 2.1mA* (< 2k Ω)
Output OFF if input < 1.2mA* (> 10k Ω)
Switching hysteresis: 0.2mA (650 Ω) nominal
*NAMUR and BS EN 60947-5-6:2001 standards
Current pulse input:
Transmitter supply: 16.5V dc at 20mA
Short circuit current: 24mA
Output: $I_{in} > 9.0mA = ON$, $I_{in} < 7.0mA = OFF$
Switching hysteresis: 0.5mA
Voltage pulse input
Input impedance: > 10k Ω
Switching point voltage (V_{sp}): 3, 6, or 12V nominal
(User selectable by switches on the side of the module)
Output: $V_{in} > V_{sp} = ON$, $V_{in} < V_{sp} = OFF$
Switching hysteresis: 100mV + (0.1 x V_{sp}) typical

Safe-area pulse output

Maximum delay: 10 μ s
Maximum off-state voltage: 35V
Maximum off-state leakage current: 10 μ A
Maximum on-state resistance: 25 Ω
Maximum on-state current: 50mA
Output OFF if supply fails
Note: LFD signal is Zener-diode protected against inductive loads

Safe-area current output

Input capture delay: 2 signal periods (5ms min.)
Signal range: 4 to 20mA
Under/over range: 0 to 22mA
Load resistance: 0 to 450 Ω @20mA
Output resistance: >1M Ω
Ripple: < 50 μ A peak-to-peak
Accuracy: better than 20 μ A at 20 $^{\circ}$ C
Temperature drift: < 1 μ A/ $^{\circ}$ C
Risetime (10% - 90%, after step change): 60 ms

Alarm output

Relay ON in alarm, 0.5A @ 35Vdc max.

MTL4532

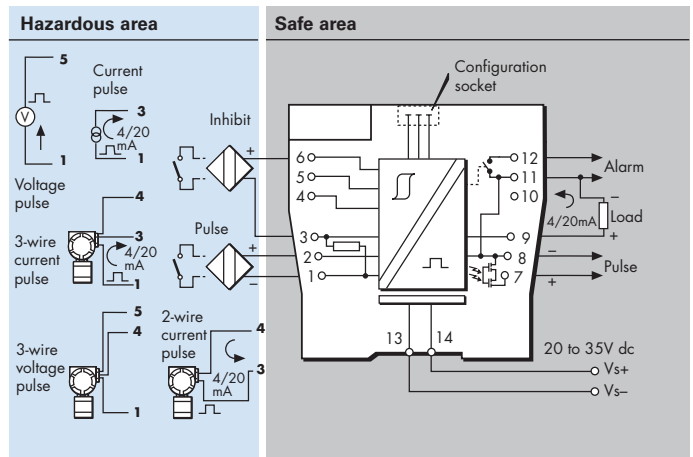

MTL5532

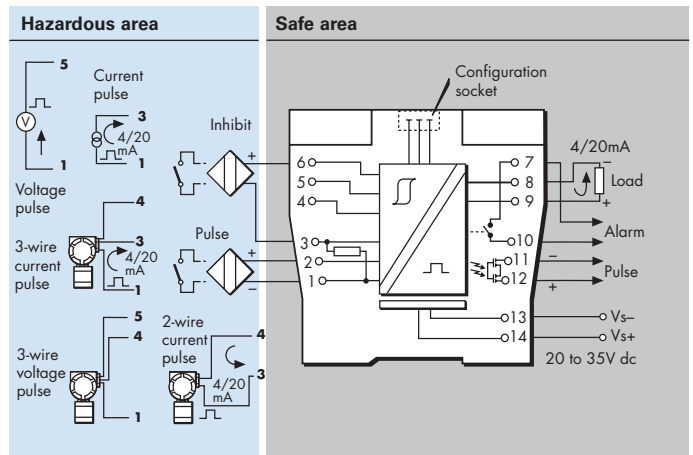

Pulse width

High: 10 μ s min
Low: 10 μ s min

Frequency range

0 - 50kHz - pulse output mode
0 - 10KHz - for analogue output

LED indicators

Green: power indication
Yellow: on when output circuit is on
Red: flashing when line fault or error

Power requirement

65mA at 24V dc
70mA at 20V dc
55mA at 35V dc

Power dissipation within unit

1.35W maximum at 24V
1.75W maximum at 35V

Safety description ($U_m = 253V$ rms or dc)

Terminals 2 to 1 and 6 to 1
 $U_o=10.5V$ $I_o=14mA$ $P_o=37mW$
Terminals 4 to 3 and 1
 $U_o=28V$ $I_o=93mA$ $P_o=651mW$
Terminals 3 to 1
Non-energy-storing apparatus $\leq 1.5V$, $\leq 0.1A$ and $\leq 25mW$; can be connected without further certification into any IS loop with an open-circuit voltage <28V
Terminals 5 to 4 and 1
 $V_{max} \leq 28V$, $I_{max} \leq 94mA$, $P_{max} \leq 0.66W$

Configurator

A personal computer running MTL PCS45 software with a PCL45USB serial interface.

The given data is only intended as a product description and should not be regarded as a legal warranty of properties or guarantee.
In the interest of further technical developments, we reserve the right to make design changes.



Powering Business Worldwide

Eaton Electric Limited,
Great Marlings, Butterfield, Luton
Beds, LU2 8DL, UK.
Tel: + 44 (0)1582 723633 Fax: + 44 (0)1582 422283
E-mail: mtlenquiry@eaton.com
www.mtl-inst.com

© 2016 Eaton
All Rights Reserved
Publication No.
EPSx532 Rev5 010916

EUROPE (EMEA):
+44 (0)1582 723633 mtlenquiry@eaton.com
THE AMERICAS:
+1 800 835 7075 mtl-us-info@eaton.com
ASIA-PACIFIC:
+65 6 645 9888 sales.mtlsing@eaton.com

MTL5533 VIBRATION TRANSDUCER INTERFACE

2-channel

The MTL5533 repeats signals from vibration sensors in a hazardous area, providing outputs for a monitoring system in the safe area. The interface is compatible with 3-wire eddy-current probes and accelerometers or 2-wire current sensors, the selection is made by switches on the side of the module.

SPECIFICATION

See also common specification

Number of channels

Two

Sensor type

2- or 3-wire vibration transducer

Location of signal source

Zone 0, IIC, T4–6 hazardous area if suitably certified
Div. 1, Group A hazardous location

Hazardous-area input

Input impedance
(terminals 2 & 3, 5 & 6): 10k Ω

Transducer supply voltage, 3-wire (terminals 3 & 1 and 6 & 4)

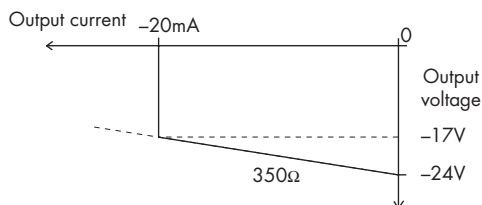

Transducer supply current, 2-wire

3.3mA (nom.) for 2-wire sensors, user selectable by switch

Signal range

Minimum -20V, maximum -0.5V

DC transfer accuracy at 20°C

< \pm 50mV

AC transfer accuracy at 20°C

0Hz to 1kHz: \pm 1%
1kHz to 10kHz: -5% to +1%
10kHz to 20kHz: -10% to +1%

Temperature coefficient

\pm 50ppm/ $^{\circ}$ C (10 to 65 $^{\circ}$ C)
 \pm 100ppm/ $^{\circ}$ C (-20 to 10 $^{\circ}$ C)

Voltage bandwidth

-3dB at 47kHz (typical)

Phase response

<14 μ s, equivalent to:
-1 $^{\circ}$ at 200Hz
-3 $^{\circ}$ at 600Hz
-5 $^{\circ}$ at 1kHz
-50 $^{\circ}$ at 10kHz
-100 $^{\circ}$ at 20kHz

Safe-area output impedance

<20 Ω

MTL5533

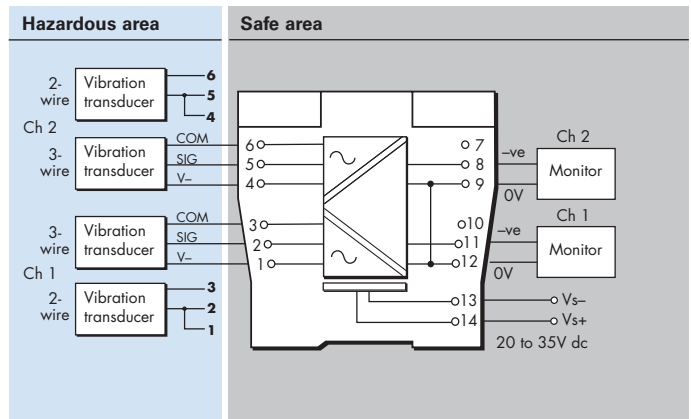

LED indicator

Green: power indication

Supply voltage

20 to 35V dc

Maximum current consumption (10mA transducer load/ch)

130mA at 24V

Maximum power dissipation within unit

2.7W

Safety description

Terminals 3 to 1 and 6 to 4
 $U_o=26.6V$ $I_o=94mA$ $P_o=0.66W$ $U_m = 253V$ rms or dc
Terminals 3 to 2 and 6 to 5
Non-energy-storing apparatus $\leq 1.5V$, $\leq 0.1A$ and $\leq 25mW$

Note -

Refer to the Instruction Manual for recommendations on mounting of these modules.

A minimum spacing of 10mm must be applied between these and any other modules on the DIN-rail.

Maximum ambient temperature with this spacing is 50 $^{\circ}$ C.



Powering Business Worldwide

Eaton Electric Limited,

Great Marlings, Butterfield, Luton
Beds, LU2 8DL, UK.
Tel: + 44 (0)1582 723633 Fax: + 44 (0)1582 422283
E-mail: mtlenquiry@eaton.com
www.mtl-inst.com

© 2016 Eaton
All Rights Reserved
Publication No.
EPSx533 Rev6 010916

EUROPE (EMEA):

+44 (0)1582 723633 mtlenquiry@eaton.com

THE AMERICAS:

+1 800 835 7075 mtl-us-info@eaton.com

ASIA-PACIFIC:

+65 6 645 9888 sales.mtlsing@eaton.com

The given data is only intended as a product description and should not be regarded as a legal warranty of properties or guarantee.
In the interest of further technical developments, we reserve the right to make design changes.

MTL4541/S – MTL5541/S

REPEATER POWER SUPPLY

4/20mA, HART®, 2- or 3-wire transmitters

The MTLx541 provides a fully-floating dc supply for energising a conventional 2- or 3-wire 4/20mA transmitter, which is located in a hazardous area, and repeats the current in another floating circuit to drive a safe-area load. For HART 2-wire transmitters, the unit allows bi-directional communications signals superimposed on the 4/20mA loop current. Alternatively, the MTLx541S acts as a current sink for a safe-area connection rather than driving a current into the load. Separately powered current sources, such as 4-wire transmitters, can be connected but will not support HART communication.

SPECIFICATION

See also common specification

Number of channels

One

Location of transmitter

Zone 0, IIC, T4–6 hazardous area if suitably certified
Div. 1, Group A hazardous location

Safe-area output

Signal range: 4 to 20mA
Under/over-range: 0 to 24mA
Safe-area load resistance (MTLx541)
@ 24mA: 0 to 360Ω
@ 20mA: 0 to 450Ω
Safe-area load (MTLx541S)
Current sink: 600Ω max.
Maximum voltage source: 24V dc
Safe-area circuit output resistance: > 1MΩ

Safe-area circuit ripple

< 50μA peak-to-peak

Hazardous-area input

Signal range: 0 to 24mA (including over-range)
Transmitter voltage: 16.5V at 20mA

Transfer accuracy at 20°C

Better than 15μA

Temperature drift

< 0.8μA/°C

Response time

Settles to within 10% of final value within 50μs

Communications supported

HART (terminals 1 & 2 only)



MTL4541 / MTL4541S

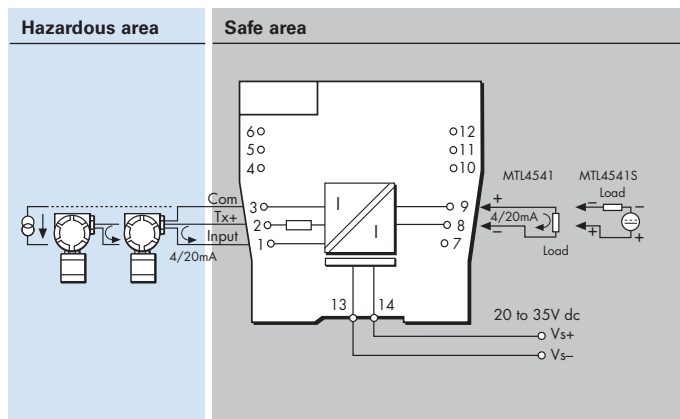

MTL5541 / MTL5541S

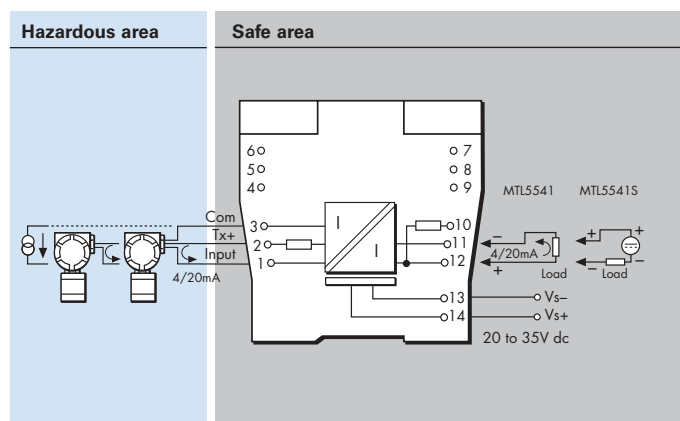

LED indicator

Green: power indication

Maximum current consumption (with 20mA signal)

51mA at 24V

Power dissipation within unit (with 20mA signal)

MTLx541 0.7W @ 24V dc
MTLx541S 1.0W @ 24V dc

Safety description

Terminals 2 to 1 and 3:

$U_o=28V$ $I_o=93mA$ $P_o=651mW$ $U_m=253V$ rms or dc

Terminals 1 to 3:

Simple apparatus $\leq 1.5V$, $\leq 0.1A$ and $\leq 25mW$; can be connected without further certification into any IS loop with an open-circuit voltage <28V



SIL capable

These models have been assessed for use in IEC 61508 functional safety applications. SIL2 capable for a single device (HFT=0) SIL3 capable for multiple devices in safety redundant configurations (HFT=1) See data on MTL web site and refer to the safety manual.



Powering Business Worldwide

Eaton Electric Limited,

Great Marlings, Butterfield, Luton
Beds, LU2 8DL, UK.
Tel: + 44 (0)1582 723633 Fax: + 44 (0)1582 422283
E-mail: mtlenquiry@eaton.com
www.mtl-inst.com

© 2016 Eaton
All Rights Reserved
Publication No.
EPSx541/S Rev6 010916

EUROPE (EMEA):

+44 (0)1582 723633 mtlenquiry@eaton.com

THE AMERICAS:

+1 800 835 7075 mtl-us-info@eaton.com

ASIA-PACIFIC:

+65 6 645 9888 sales.mtlsing@eaton.com

The given data is only intended as a product description and should not be regarded as a legal warranty of properties or guarantee. In the interest of further technical developments, we reserve the right to make design changes.

MTL4541A/AS – MTL5541A/AS CURRENT REPEATER

4/20mA passive i/p for HART® transmitters

The MTLx541A provides an input for separately powered 4/20mA transmitters and also allows bi-directional transmission of HART communication signals superimposed on the 4/20mA loop current. Alternatively, the MTLx541AS acts as a current sink for a safe-area connection rather than driving a current into the load.

SPECIFICATION

See also common specification



Number of channels

One

Location of transmitter

Zone 0, IIC, T4–6 hazardous area if suitably certified
Div.1, Group A, hazardous location

Hazardous area input

Signal range: 4 to 20mA
Under/over-range: 1.0 to 21.5mA

Input impedance for HART signals

at terminals 1, 2: > 230Ω

Maximum input volt drop

at terminals 1, 2: < 6.6V
i.e. a transmitter load of 330Ω at 20mA

Safe-area output

Signal range: 4 to 20mA
Under/over-range: 1.0 to 21.5mA

Safe-area load resistance (MTLx541A)

Conventional transmitters: 0 to 360Ω

Smart transmitters: 250Ω ±10%

Safe-area load (MTLx541AS)

Current sink: 600Ω max.

Maximum voltage source: 24V DC

Safe-area circuit output resistance: > 1MΩ

Safe-area circuit ripple

< 50μA peak-to-peak up to 80kHz

Transfer accuracy at 20°C

Better than 20μA

Temperature drift

< 1μA/°C

Response time

Settles within 200μA of final value after 20ms

Communications supported

HART

LED indicator

Green: power indication

Power requirement (with 20mA signal)

50mA at 20V

45mA at 24V

35mA at 35V

MTL4541A / MTL4541AS

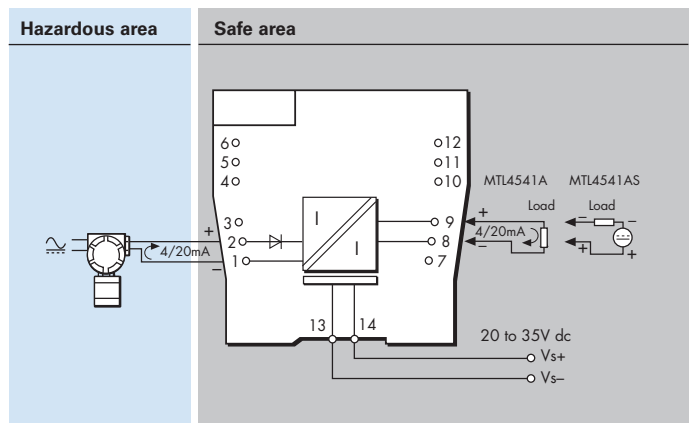

MTL5541A / MTL5541AS

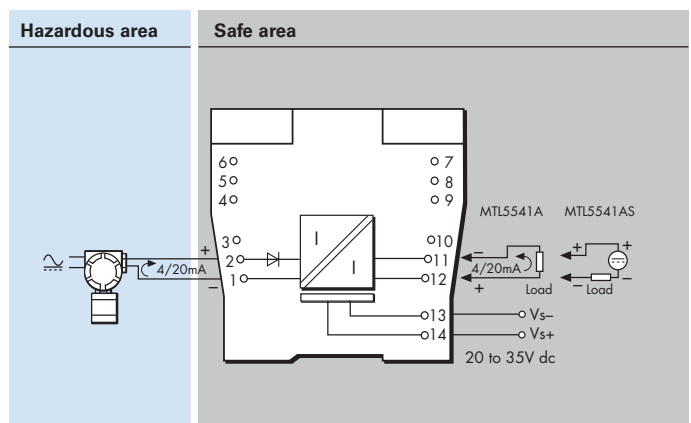

Power dissipation within unit (with 20mA signals)

MTLx541A 0.8W @ 24V dc

MTLx541AS 1.1W @ 24V dc

Safety description

Terminals 1 to 2:

$U_m = 253V$ rms or dc.

8.6V (diode). This voltage must be considered when calculating the load capacitance.

Non-energy-storing apparatus ≤1.5V, ≤0.1A and ≤25mW; can be connected without further certification into any IS loop with an open-circuit voltage <28V



SIL capable

These models have been assessed for use in IEC 61508 functional safety applications.

SIL2 capable for a single device (HFT=0)

SIL3 capable for multiple devices in safety redundant configurations (HFT=1)

See data on MTL web site and refer to the safety manual.



Powering Business Worldwide

Eaton Electric Limited,

Great Marlings, Butterfield, Luton
Beds, LU2 8DL, UK.

Tel: + 44 (0)1582 723633 Fax: + 44 (0)1582 422283

E-mail: mtlenquiry@eaton.com

www.mtl-inst.com

© 2016 Eaton

All Rights Reserved

Publication No.

EPSx541A/AS Rev5 010916

EUROPE (EMEA):

+44 (0)1582 723633 mtlenquiry@eaton.com

THE AMERICAS:

+1 800 835 7075 mtl-us-info@eaton.com

ASIA-PACIFIC:

+65 6 645 9888 sales.mtlsing@eaton.com

The given data is only intended as a product description and should not be regarded as a legal warranty of properties or guarantee.

In the interest of further technical developments, we reserve the right to make design changes.

MTL4541T REPEATER POWER SUPPLY

4/20mA, 2- or 3-wire transmitters using long field lines

The MTL4541T provides a fully-floating dc supply for energising a conventional 2- or 3-wire 4/20mA transmitter, which is located in a hazardous area, and repeats the current in another floating circuit to drive a safe-area load. For HART 2-wire transmitters, the unit allows bi-directional communications signals superimposed on the 4/20mA loop current. Separately powered current sources, such as 4-wire transmitters, can be connected but will not support HART communication. The reduced maximum open-circuit voltage permits the use of longer field lines compared to MTL4541.

SPECIFICATION

See also common specification

Number of channels

One

Location of transmitter

Zone 0, IIC, T4–6 hazardous area if suitably certified
Div. 1, Group A hazardous location

Safe-area output

Signal range: 4 to 20mA
Under/over-range: 0 to 24mA
Safe-area load resistance
@ 24mA: 0 to 250Ω
@ 20mA: 0 to 325Ω

Safe-area circuit ripple

< 50μA peak-to-peak

Hazardous-area input

Signal range: 0 to 24mA (including over-range)
Transmitter voltage: 14V at 20mA

Transfer accuracy at 20°C

Better than 15μA

Temperature drift

< 0.8μA/°C

Response time

Settles to within 10% of final value within 50μs

Communications supported

HART (terminals 1 & 2 only)

MTL4541T

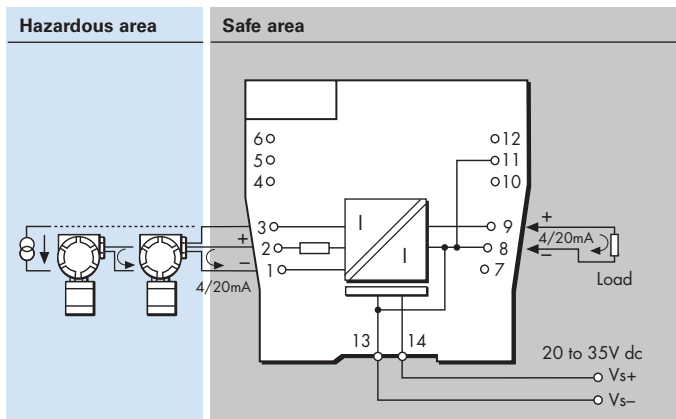

LED indicator

Green: power indication

Maximum current consumption (with 20mA signal)

51mA at 24V

Power dissipation within unit (with 20mA signal)

0.7W @ 24V dc

Safety description

Terminals 2 to 1:

$V_o=22V$ $I_o=167mA$ $P_o=920mW$ $U_m = 253V$ rms or dc

Terminals 3 to 1:

Simple apparatus $\leq 1.5V$, $\leq 0.1A$ and $\leq 25mW$; can be connected without further certification into any IS loop with an open-circuit voltage <28V



Powering Business Worldwide

Eaton Electric Limited,

Great Marlings, Butterfield, Luton
Beds, LU2 8DL, UK.
Tel: + 44 (0)1582 723633 Fax: + 44 (0)1582 422283
E-mail: mtlenquiry@eaton.com
www.mtl-inst.com

© 2016 Eaton
All Rights Reserved
Publication No.
EPS4541T Rev2 010916

EUROPE (EMEA):

+44 (0)1582 723633 mtlenquiry@eaton.com

THE AMERICAS:

+1 800 835 7075 mtl-us-info@eaton.com

ASIA-PACIFIC:

+65 6 645 9888 sales.mtlsing@eaton.com

The given data is only intended as a product description and should not be regarded as a legal warranty of properties or guarantee.
In the interest of further technical developments, we reserve the right to make design changes.

MTL4544/S – MTL5544/S REPEATER POWER SUPPLY

2-channel, 4/20mA, HART®, 2- or 3- wire transmitters

The MTLx544 provides fully-floating dc supplies for energising two conventional 2-wire or 3-wire 4/20mA or HART transmitters located in a hazardous area, and repeats the current in other circuits to drive two safe-area loads. For smart transmitters, the unit allows bi-directional transmission of digital communication signals superimposed on the 4/20mA loop current. Alternatively, the MTLx544S acts as a current sink for a safe-area connection rather than driving a current into the load. Separately powered current sources, such as 4-wire transmitters, can be connected but will not support HART communication.

SPECIFICATION

See also common specification

Number of channels

Two

Location of transmitter

Zone 0, IIC, T4–6 hazardous area if suitably certified
Div. 1, Group A hazardous location

Safe-area output

Signal range: 4 to 20mA
Under/over-range: 0 to 24mA
Safe-area load resistance (MTLx544)
@ 24mA: 0 to 360Ω
@ 20mA: 0 to 450Ω
Safe-area load (MTLx544S)
Current sink: 600Ω max.
Maximum voltage source: 24V dc
Safe-area circuit output resistance: > 1MΩ

Safe-area circuit ripple

< 50μA peak-to-peak

Hazardous-area input

Signal range: 0 to 24mA (including over-range)
Transmitter voltage: 16.5V at 20mA

Transfer accuracy at 20°C

Better than 15μA

Temperature drift

< 0.8μA/°C

Response time

Settles to within 10% of final value within 50μs

Communications supported

HART (terminals 1 & 2 and 4 & 5 only)



MTL4544 / MTL4544S

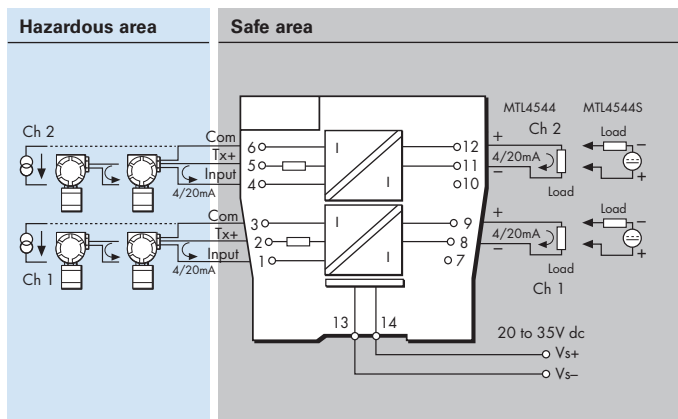

MTL5544 / MTL5544S

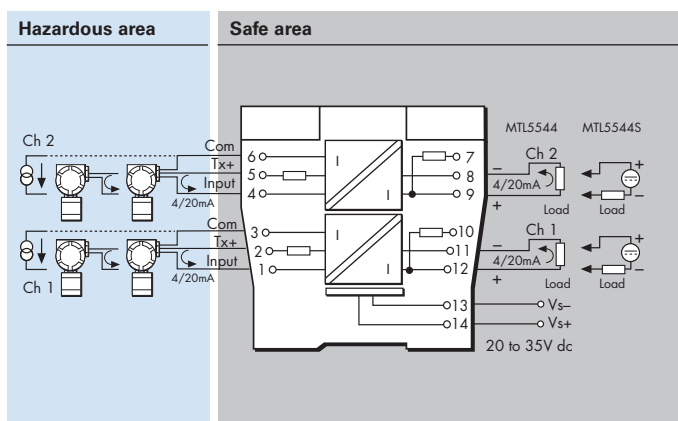

LED indicator

Green: power indication

Maximum current consumption (with 20mA signals)

96mA at 24V dc

Power dissipation within unit (with 20mA signals)

MTLx544 1.4W @ 24V dc
MTLx544S 1.9W @ 24V dc

Safety description (each channel)

Terminals 2 to 1 and 3, and 5 to 4 and 6:
 $U_o=28V$ $I_o=93mA$ $P_o=651mW$ $U_m=253V$ rms or dc
Terminals 1 to 3 and 4 to 6:
Simple apparatus $\leq 1.5V$, $\leq 0.1A$ and $\leq 25mW$; can be connected without further certification into any IS loop with an open-circuit voltage <28V



SIL capable

These models have been assessed for use in IEC 61508 functional safety applications.
SIL2 capable for a single device (HFT=0)
SIL3 capable for multiple devices in safety redundant configurations (HFT=1)
See data on MTL web site and refer to the safety manual.



Powering Business Worldwide

Eaton Electric Limited,
Great Marlings, Butterfield, Luton
Beds, LU2 8DL, UK.
Tel: +44 (0)1582 723633 Fax: +44 (0)1582 422283
E-mail: mtlenquiry@eaton.com
www.mtl-inst.com

© 2016 Eaton
All Rights Reserved
Publication No.
EPSx544/S Rev6 010916

EUROPE (EMEA):
+44 (0)1582 723633 mtlenquiry@eaton.com
THE AMERICAS:
+1 800 835 7075 mtl-us-info@eaton.com
ASIA-PACIFIC:
+65 6 645 9888 sales.mtlsing@eaton.com

The given data is only intended as a product description and should not be regarded as a legal warranty of properties or guarantee.
In the interest of further technical developments, we reserve the right to make design changes.

MTL4544A/AS – MTL5544A/AS CURRENT REPEATER

4/20mA passive i/p for HART® transmitters

The MTLx544A provides an input for separately powered 4/20mA transmitters and also allows bi-directional transmission of HART communication signals superimposed on the 4/20mA loop current, so that the transmitter can be interrogated either from the operator station or by a hand-held communicator (HHC). Alternatively, the MTLx544AS acts as a current sink for a safe-area connection rather than driving a current into the load.

SPECIFICATION

See also common specification



Number of channels

Two

Location of transmitter

Zone 0, IIC, T4–6 hazardous area if suitably certified
Div.1, Group A, hazardous location

Hazardous area input

Signal range: 4 to 20mA
Under/over-range: 1.0 to 21.5mA

Input impedance for HART signals

at terminals 1, 2 and 4, 5: > 230Ω

Maximum input volt drop

at terminals 1, 2 and 4, 5: < 6.6V
i.e. a transmitter load of 330Ω at 20mA

Safe-area output

Signal range: 4 to 20mA
Under/over-range: 1.0 to 21.5mA

Safe-area load resistance (MTL5544A)

Conventional transmitters: 0 to 360Ω
Smart transmitters: 250Ω ±10%

Safe-area load (MTL5544AS)

Current sink: 600Ω max.

Maximum voltage source: 24V DC

Safe-area circuit output resistance: > 1MΩ

Safe-area circuit ripple

< 50μA peak-to-peak up to 80kHz

Transfer accuracy at 20°C

Better than 20μA

Temperature drift

< 1μA/°C

Response time

Settles within 200μA of final value after 20ms

Communications supported

HART

LED indicator

Green: power indication

Power requirement (with 20mA signal)

70mA at 24V
85mA at 20V
50mA at 35V

MTL4544A / MTL4544AS

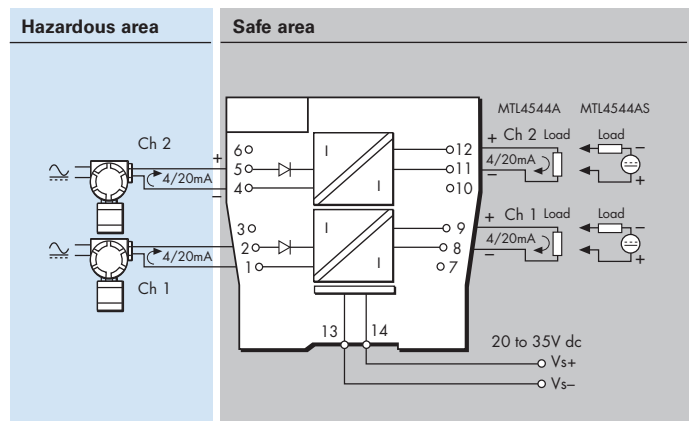

MTL5544A / MTL5544AS

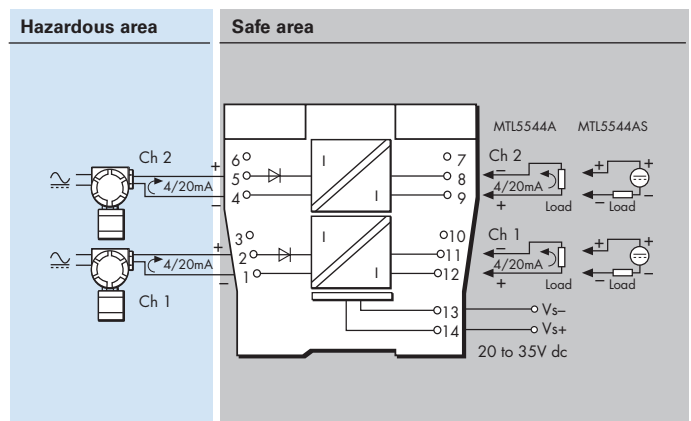

Power dissipation within unit (with 20mA signals)

MTLx544A 1.5W @ 24V dc
MTLx544AS 2.0W @ 24V dc

Safety description

Terminals 1 to 2 and 4 to 5:

$U_m = 253V$ rms or dc.

8.6V (diode). This voltage must be considered when calculating the load capacitance.

Non-energy-storing apparatus ≤1.5V, ≤0.1A and ≤25mW; can be connected without further certification into any IS loop with an open-circuit voltage < 28V



SIL capable

These models have been assessed for use in IEC 61508 functional safety applications.

SIL2 capable for a single device (HFT=0)

SIL3 capable for multiple devices in safety redundant configurations (HFT=1)

See data on MTL web site and refer to the safety manual.



Powering Business Worldwide

Eaton Electric Limited,

Great Marlings, Butterfield, Luton
Beds, LU2 8DL, UK.
Tel: + 44 (0)1582 723633 Fax: + 44 (0)1582 422283
E-mail: mtlenquiry@eaton.com
www.mtl-inst.com

© 2016 Eaton
All Rights Reserved
Publication No.
EPSx544A/AS Rev5 010916

EUROPE (EMEA):

+44 (0)1582 723633 mtlenquiry@eaton.com

THE AMERICAS:

+1 800 835 7075 mtl-us-info@eaton.com

ASIA-PACIFIC:

+65 6 645 9888 sales.mtlsing@eaton.com

The given data is only intended as a product description and should not be regarded as a legal warranty of properties or guarantee. In the interest of further technical developments, we reserve the right to make design changes.

MTL4544D – MTL5544D REPEATER POWER SUPPLY

single channel, 4/20mA, HART®
for 2- or 3-wire transmitters, two outputs

The MTLx544D provides a fully-floating dc supply for energising a conventional 2- or 3-wire 4/20mA transmitter located in a hazardous area, and repeats the current in other circuits to drive two safe-area loads. For HART 2-wire transmitters, the unit allows bi-directional transmission of digital communication signals superimposed on the 4/20mA loop current. Separately powered current sources, such as 4-wire transmitters, can be connected but will not support HART communication.

SPECIFICATION

See also common specification



Number of channels

One

Location of transmitter

Zone 0, IIC, T4–6 hazardous area if suitably certified
Div. 1, Group A hazardous location

Safe-area output

Signal range: 4 to 20mA
Under/over-range: 0 to 24mA
Safe-area load resistance
@ 24mA: 0 to 360Ω
@ 20mA: 0 to 450Ω
Safe-area circuit output resistance: > 1MΩ

Safe-area circuit ripple

< 50μA peak-to-peak

Hazardous-area input

Signal range: 0 to 24mA (including over-range)
Transmitter voltage: 16.5V at 20mA

Transfer accuracy at 20°C

Better than 15μA

Temperature drift

< 0.8μA/°C

Response time

Settles to within 10% of final value within 50μs

Communications supported

HART (terminals 1 & 2, output Ch 1 only)

MTL4544D

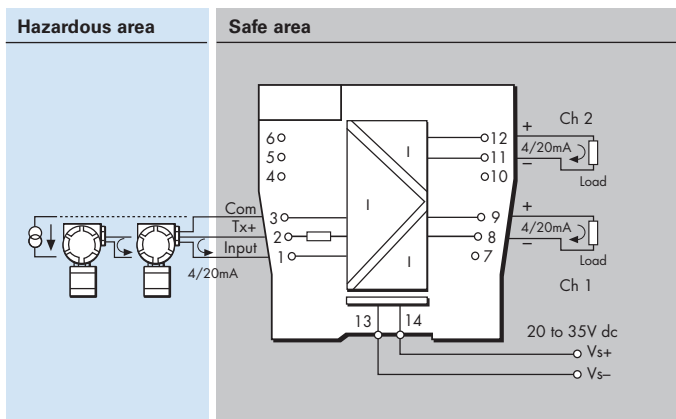

MTL5544D

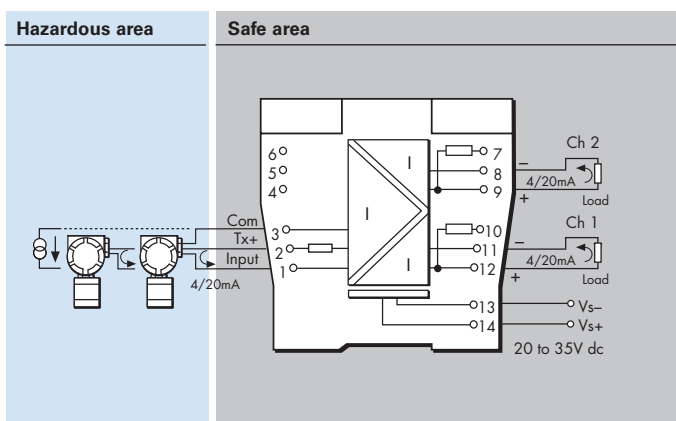

LED indicator

Green: power indication

Maximum current consumption (with 20mA signals)

96mA at 24V dc

Power dissipation within unit (with 20mA signals)

1.4W @ 24V dc

Safety description

Terminals 2 to 1 and 3:

$U_o=28V$ $I_o=93mA$ $P_o=651mW$ $U_m=253V$ rms or dc

Terminals 1 to 3:

Simple apparatus $\leq 1.5V$, $\leq 0.1A$ and $\leq 25mW$; can be connected without further certification into any IS loop with an open-circuit voltage <28V



SIL capable

These models have been assessed for use in IEC 61508 functional safety applications. SIL2 capable for a single device (HFT=0) SIL3 capable for multiple devices in safety redundant configurations (HFT=1) See data on MTL web site and refer to the safety manual.



Powering Business Worldwide

Eaton Electric Limited,

Great Marlings, Butterfield, Luton
Beds, LU2 8DL, UK.
Tel: + 44 (0)1582 723633 Fax: + 44 (0)1582 422283
E-mail: mtlenquiry@eaton.com
www.mtl-inst.com

© 2016 Eaton
All Rights Reserved
Publication No.
EPSx544D Rev7 010916

EUROPE (EMEA):

+44 (0)1582 723633 mtlenquiry@eaton.com

THE AMERICAS:

+1 800 835 7075 mtl-us-info@eaton.com

ASIA-PACIFIC:

+65 6 645 9888 sales.mtlsing@eaton.com

The given data is only intended as a product description and should not be regarded as a legal warranty of properties or guarantee.

In the interest of further technical developments, we reserve the right to make design changes.

MTL4546/C/Y – MTL5546/Y ISOLATING DRIVER

for 4–20mA HART® valve positioners
with line fault detection

The MTLx546 accepts a 4/20mA floating signal from a safe-area controller to drive a current/pressure converter (or any other load up to 800Ω) in a hazardous area. For HART valve positioners, the module also permits bi-directional transmission of digital communication signals. Process controllers with a readback facility can detect open or short circuits in the field wiring: if these occur, the current taken into the terminals drops to a preset level. The MTL4546C and the MTLx546Y are very similar to the MTLx546 except that they provide open circuit detection only (i.e. no short-circuit detection).

SPECIFICATION

See also common specification

Number of channels

One

Location of I/P converter

Zone 0, IIC, T4–6 hazardous area if suitably certified
Div. 1, Group A, hazardous location

Working range

4 to 20mA

Digital signal bandwidth

500Hz to 10kHz

Maximum load resistance

800Ω (16V at 20mA)

Minimum load resistance

90Ω (short-circuit detection at < 50Ω)

Output resistance

> 1MΩ

Under/over range capability

Under range = 1mA
Over range = 24mA (load ≤ 520Ω)

Input and output circuit ripple

< 40μA peak-to-peak

Transfer accuracy at 20°C

Better than 20μA

Temperature drift

< 1.0μA/°C

Input characteristics

| Field wiring state | MTLx546 | MTL4546C | MTLx546Y |
|--------------------|---------|----------|----------|
| Normal | < 6.0V | < 6.0V | < 6.0V |
| Open-circuit | < 0.9mA | < 0.9mA | < 0.5mA |
| Short-circuit | < 0.9mA | N.A. | N.A. |

Response time

Settles within 200μA of final value within 100ms

Communications supported

HART



MTL4546 / MTL4546C / MTL4546Y

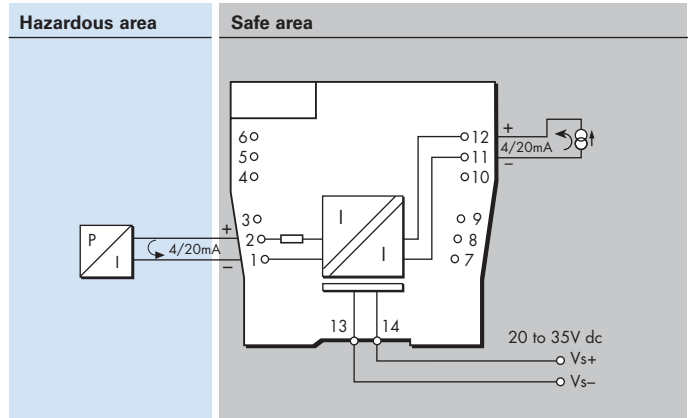

MTL5546 / MTL5546Y

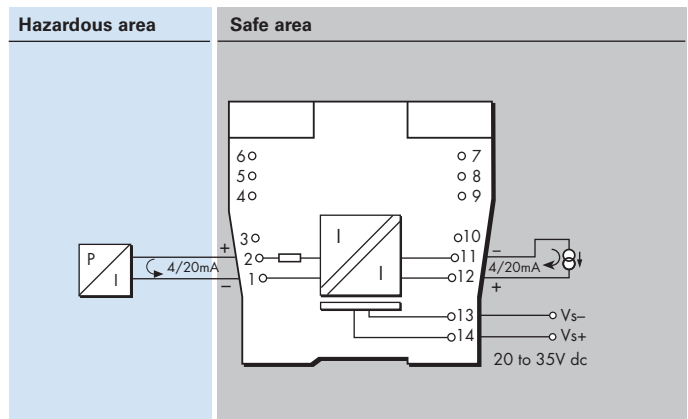

LED indicator

Green: power indication

Maximum current consumption (with 20mA signals into 250Ω load)

35mA at 24V dc

Power dissipation within unit (with 20mA signals into 250Ω load)

0.8W at 24V

Safety description

$U_o = 28V$ $I_o = 93mA$ $P_o = 651mW$ $U_m = 253V$ rms or dc



SIL capable

These models have been assessed for use in IEC 61508 functional safety applications. SIL2 capable for a single device (HFT=0) SIL3 capable for multiple devices in safety redundant configurations (HFT=1) See data on MTL web site and refer to the safety manual.



Powering Business Worldwide

Eaton Electric Limited,

Great Marlings, Butterfield, Luton
Beds, LU2 8DL, UK.
Tel: + 44 (0)1582 723633 Fax: + 44 (0)1582 422283
E-mail: mtlenquiry@eaton.com
www.mtl-inst.com

© 2016 Eaton
All Rights Reserved
Publication No.
EPSx546/C/Y Rev6 010916

EUROPE (EMEA):

+44 (0)1582 723633 mtlenquiry@eaton.com

THE AMERICAS:

+1 800 835 7075 mt-us-info@eaton.com

ASIA-PACIFIC:

+65 6 645 9888 sales.mtlsing@eaton.com

The given data is only intended as a product description and should not be regarded as a legal warranty of properties or guarantee. In the interest of further technical developments, we reserve the right to make design changes.

MTL4546S ISOLATING DRIVER

for 4–20mA HART® valve positioners with line fault detection and long field lines

The MTL4546S accepts a 4/20mA floating signal from a safe-area controller to drive a current/pressure converter (or any other load up to 710Ω) in a hazardous area. For HART valve positioners, the module also permits bi-directional transmission of digital communication signals. Process controllers with a readback facility can detect open circuits in the field wiring: if these occur, the current taken into the terminals drops to a preset level. The reduced maximum open-circuit voltage permits the use of longer field lines compared to MTL4546

SPECIFICATION

See also common specification

Number of channels

One

Location of I/P converter

Zone 0, IIC, T4–6 hazardous area if suitably certified
Div. 1, Group A, hazardous location

Working range

4 to 20mA

Digital signal bandwidth

500Hz to 10kHz

Maximum load resistance

710Ω (14.2V at 20mA)

Minimum load resistance

90Ω

Output resistance

> 1MΩ

Under/over range capability

Under range = 1mA
Over range = 24mA (load ≤ 520Ω)

Input and output circuit ripple

< 40μA peak-to-peak

Transfer accuracy at 20°C

Better than 20μA

Temperature drift

< 1.0μA/°C

Input characteristics

| Field wiring state | |
|--------------------|---------|
| Normal | < 6.0V |
| Open-circuit | < 0.9mA |
| Short-circuit | N.A. |

Response time

Settles within 200μA of final value within 100ms

Communications supported

HART

MTL4546S

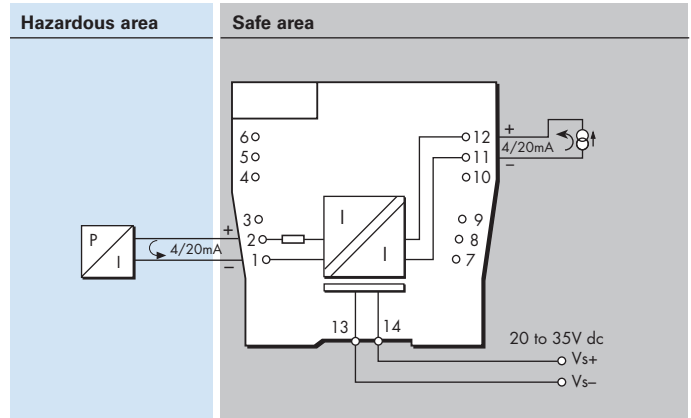

LED indicator

Green: power indication

Maximum current consumption (with 20mA signals into 250Ω load)

35mA at 24V dc

Power dissipation within unit (with 20mA signals into 250Ω load)

0.8W at 24V

Safety description

$V_o=22V$ $I_o=100mA$ $P_o=550mW$ $U_m = 253V$ rms or dc



Powering Business Worldwide

Eaton Electric Limited,

Great Marlings, Butterfield, Luton
Beds, LU2 8DL, UK.
Tel: + 44 (0)1582 723633 Fax: + 44 (0)1582 422283
E-mail: mtlenquiry@eaton.com
www.mtl-inst.com

© 2016 Eaton
All Rights Reserved
Publication No.
EPS4546S Rev2 010916

EUROPE (EMEA):

+44 (0)1582 723633 mtlenquiry@eaton.com

THE AMERICAS:

+1 800 835 7075 mtl-us-info@eaton.com

ASIA-PACIFIC:

+65 6 645 9888 sales.mtlsing@eaton.com

The given data is only intended as a product description and should not be regarded as a legal warranty of properties or guarantee. In the interest of further technical developments, we reserve the right to make design changes.

MTL4549/C/Y - MTL5549/Y

ISOLATING DRIVER

two-channel, for 4–20mA, HART®
valve positioners with line fault detection

The MTLx549 accepts 4/20mA floating signals from safe-area controllers to drive 2 current/pressure converters (or any other load up to 800Ω) in a hazardous area. For HART valve positioners, the module also permits bi-directional transmission of digital communication signals. Process controllers with a readback facility can detect open or short circuits in the field wiring: if these occur, the current taken into the terminals drops to a preset level. The MTL4549C and MTLx549Y are very similar to the MTLx549 except that they provide open circuit detection only (i.e. no short-circuit detection).

SPECIFICATION

See also common specification

Number of channels

Two

Location of I/P converter

Zone 0, IIC, T4–6 hazardous area if suitably certified
Div. 1, Group A, hazardous location

Working range

4 to 20mA

Digital signal bandwidth

500Hz to 10kHz

Maximum load resistance

800Ω (16V at 20mA)

Minimum load resistance

90Ω (short-circuit detection at < 50Ω)

Output resistance

> 1MΩ

Under/over range capability

Under range = 1mA
Over range = 24mA (load ≤ 520Ω)

Input and output circuit ripple

<40μA peak-to-peak

Communications supported

HART

Transfer accuracy at 20°C

Better than 20μA

Temperature drift

< 1.0μA/°C

Input characteristics

| Field wiring state | MTL4549 | MTL4549C | MTL4549Y |
|--------------------|---------|----------|----------|
| Normal | < 6.0V | < 6.0V | < 6.0V |
| Open-circuit | < 0.9mA | < 0.9mA | < 0.5mA |
| Short-circuit | < 0.9mA | N.A. | N.A. |

Response time

Settles within 200μA of final value within 100ms



MTL4549 / MTL4549C / MTL4549Y

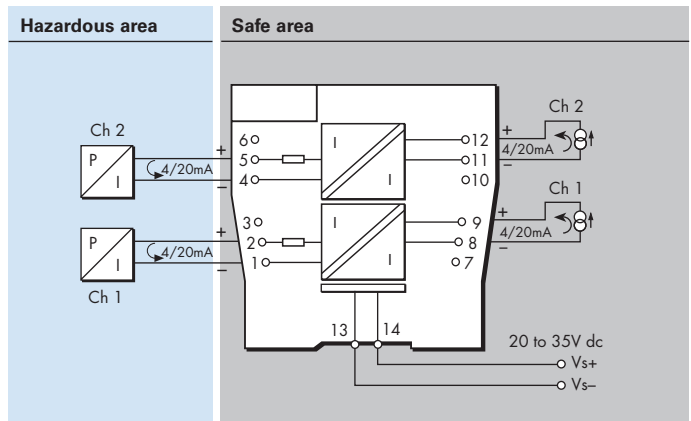

MTL5549 / MTL5549Y

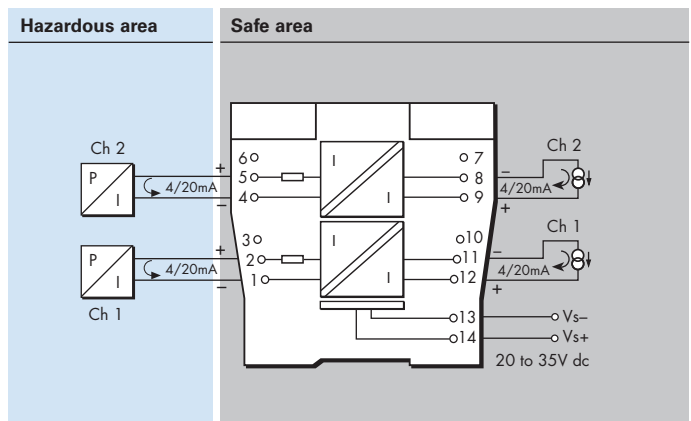

LED indicator

Green: power indication

Maximum current consumption (with 20mA signals into 250Ω load)

70mA at 24V dc

Power dissipation within unit (with 20mA signals into 250Ω load)

1.6W at 24V

Safety description (each channel)

$U_o=28V$ $I_o=93mA$ $P_o=0.65W$ $U_m=253V$ rms or dc



SIL capable

These models have been assessed for use in IEC 61508 functional safety applications. SIL2 capable for a single device (HFT=0) SIL3 capable for multiple devices in safety redundant configurations (HFT=1) See data on MTL web site and refer to the safety manual.



Powering Business Worldwide

Eaton Electric Limited,

Great Marlings, Butterfield, Luton
Beds, LU2 8DL, UK.
Tel: + 44 (0)1582 723633 Fax: + 44 (0)1582 422283
E-mail: mtlenquiry@eaton.com
www.mtl-inst.com

© 2016 Eaton
All Rights Reserved
Publication No.
EPSx549/C/Y Rev6 010916

EUROPE (EMEA):

+44 (0)1582 723633 mtlenquiry@eaton.com

THE AMERICAS:

+1 800 835 7075 mt-us-info@eaton.com

ASIA-PACIFIC:

+65 6 645 9888 sales.mtlsing@eaton.com

The given data is only intended as a product description and should not be regarded as a legal warranty of properties or guarantee. In the interest of further technical developments, we reserve the right to make design changes.

MTL4561 – MTL5561 FIRE AND SMOKE DETECTOR INTERFACE

2-channel

The MTLx561 is a loop-powered 2-channel interface for use with conventional fire and smoke detectors located in hazardous areas. In operation, the triggering of a detector causes a corresponding change in the safe-area current. The unit features reverse input polarity protection.

SPECIFICATION

See also common specification

Number of channels

Two, fully floating, loop powered

Location of fire and smoke detectors

Zone 0, IIC, T4–6 hazardous area if suitably certified
Div. 1, Group A, hazardous area

Input voltage

6 to 30V dc

Current range

1 to 40mA, nominal

Quiescent safe-area current at 20°C

(hazardous-area terminals open circuit)
< 400µA at $V_{in} = 24V$ per channel

Integral input polarity protection

Input circuit protected against reverse polarity

Minimum output voltage V_{out} at 20°C

For $V_{in} \leq 25V$: $V_{out} = V_{in} - (0.38 \times \text{current in mA}) - 2V$
For $V_{in} > 25V$: $V_{out} = 22.5V - (0.35 \times \text{current in mA})$

Maximum output voltage

28V from 300Ω

Transfer accuracy at 20°C

Better than 400µA

Temperature drift

< 4µA/°C (0°C to 60°C)
< 15µA/°C (-20°C to 0°C)

Response time to step input

Settles to within 5% of final value within 1.5ms

Power dissipation within unit

0.7W maximum at 24V with 40mA signal (each channel)
0.9W maximum at 30V with 40mA signal (each channel)

Safety description for each channel

$U_o=28V$ $I_o=93mA$ $P_o=0.65W$ $U_m = 253V$ rms or dc



MTL4561

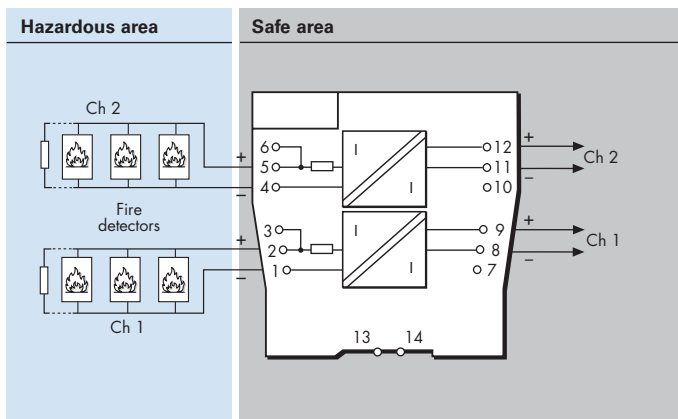

MTL5561

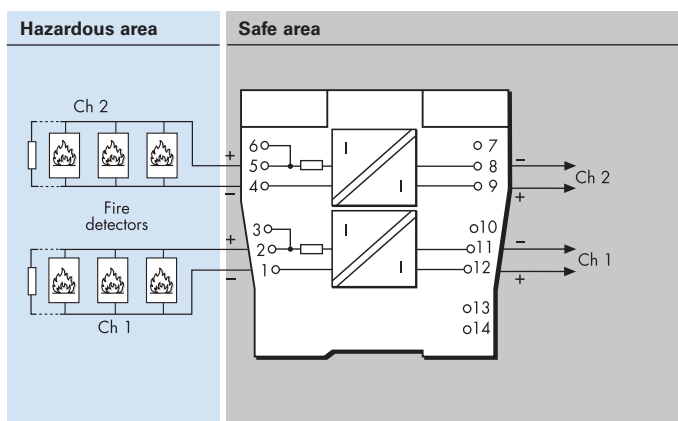

*Signal plug HAZ1-3 is required for access to this function



SIL capable

These models have been assessed for use in IEC 61508 functional safety applications. SIL2 capable for a single device (HFT=0) SIL3 capable for multiple devices in safety redundant configurations (HFT=1)
See data on MTL web site and refer to the safety manual.



Powering Business Worldwide

Eaton Electric Limited,
Great Marlings, Butterfield, Luton
Beds, LU2 8DL, UK.
Tel: +44 (0)1582 723633 Fax: +44 (0)1582 422283
E-mail: mtlenquiry@eaton.com
www.mtl-inst.com

© 2016 Eaton
All Rights Reserved
Publication No.
EPSx561 Rev7 010916

EUROPE (EMEA):
+44 (0)1582 723633 mtlenquiry@eaton.com
THE AMERICAS:
+1 800 835 7075 mtl-us-info@eaton.com
ASIA-PACIFIC:
+65 6 645 9888 sales.mtlsing@eaton.com

The given data is only intended as a product description and should not be regarded as a legal warranty of properties or guarantee. In the interest of further technical developments, we reserve the right to make design changes.

MTL4573 – MTL5573 TEMPERATURE CONVERTER

THC or RTD input

The MTLx573 converts a low-level dc signal from a temperature sensor mounted in a hazardous area into a 4/20mA current for driving a safe-area load. Software selectable features include linearisation, ranging, monitoring, testing and tagging for all thermocouple types and 2-, 3- or 4-wire RTDs. (For thermocouple applications the HAZ-CJC plug on terminals 1–3 includes an integral CJC sensor). Configuration is carried out using a personal computer.

SPECIFICATION

See also common specification

Number of channels

One

Location of signal source

Zone 0, IIC, Hazardous area

Division 1, Groups A-D, hazardous location

Signal source

| Input | Type | | Min. span |
|----------------------|----------------------|--------------------|------------|
| THC | J,K,T,E,R,S,B,N | BS EN 60584-1:1996 | 3mV |
| | XK | GOST P8.585-2001 | |
| mV | -75 to +75mV | | 3mV |
| RTD 2/3/4 wire | Pt100, Pt500, Pt1000 | BS EN 60751:2008 | 10,50,100Ω |
| | Cu-50, Cu-53 | GOST 6651-94 | 10Ω |
| | Ni100, Ni500, Ni1000 | DIN43760:1985 | 10,50,100Ω |
| Resistance | 0 to 400Ω | | 10Ω |

RTD excitation current

200µA nominal

Cold junction compensation, THC input

Selectable ON or OFF

Cold junction compensation error

≤ 1.0°C

Common mode rejection

120dB for 240V at 50Hz or 60Hz

Series mode rejection

40dB for 50Hz or 60Hz

Calibration accuracy (at 20°C)

(includes hysteresis, non-linearity and repeatability)

Inputs:

mV/THC: ± 15µV or ± 0.05% of input value
(whichever is greater)

Pt 100 - RTD: ± 80mΩ

Output: ± 11µA

Temperature drift (typical)

Inputs:

mV/THC: ± 0.003% of input value/°C

Pt 100 - RTD: ± 7mΩ/°C

Output: ± 0.6µA/°C

Example of calibration accuracy and temperature drift (RTD input)

Span: 250Ω

Accuracy: ± (0.08/250 + 11/16000) × 100%
= 0.1% of span

Temperature drift: ± (0.007/250 × 16000 + 0.6) µA/°C
= ±1.0µA/°C

Safety drive on sensor failure

Upscale, downscale, or off

MTL4573

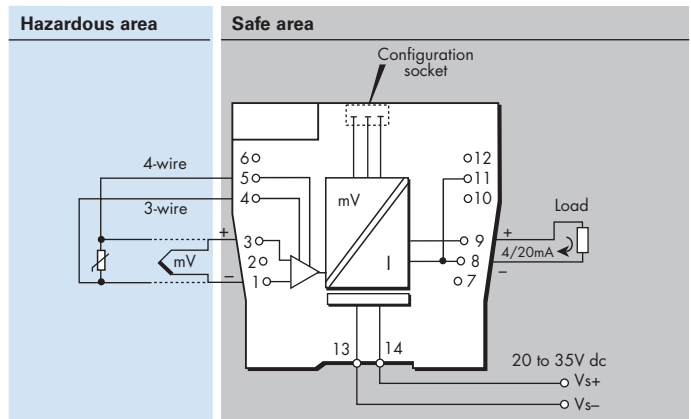

MTL5573

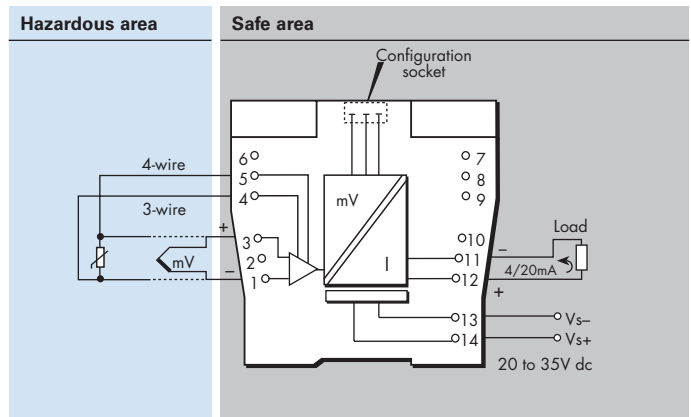

Early burnout

Early burnout detection for thermocouples (when selected)
EBD indicated when loop resistance increase is > 50Ω

Output range

4 to 20mA nominal into 600Ω max.

Out of range characteristic - MTL or NAMUR NE43

Maximum lead resistance (THC)

600Ω

Response time

Typical 500 ms

LED indicator

Green: EBD alarm indication, power and status indication
Yellow: alarm indication

Maximum current consumption (with 20mA signal)

50mA at 24V

Power dissipation within unit (with 20mA signal)

1.2W at 24V

Safety description

Refer to certificate for parameters. $U_m=253V$ rms or dc

Configurator

A personal computer running MTL PCS45 software with a PCL45USB serial interface.

The given data is only intended as a product description and should not be regarded as a legal warranty of properties or guarantee. In the interest of further technical developments, we reserve the right to make design changes.



Powering Business Worldwide

Eaton Electric Limited,

Great Marlings, Butterfield, Luton
Beds, LU2 8DL, UK.
Tel: + 44 (0)1582 723633 Fax: + 44 (0)1582 422283
E-mail: mtlenquiry@eaton.com
www.mtl-inst.com

© 2016 Eaton
All Rights Reserved
Publication No.
EPSx573 Rev2 010916

EUROPE (EMEA):

+44 (0)1582 723633 mtlenquiry@eaton.com

THE AMERICAS:

+1 800 835 7075 mt-us-info@eaton.com

ASIA-PACIFIC:

+65 6 645 9888 sales.mtlsing@eaton.com

MTL4575 – MTL5575

TEMPERATURE CONVERTER

THC or RTD input + Alarm

The MTLx575 converts a low-level dc signal from a temperature sensor mounted in a hazardous area into a 4/20mA current for driving a safe-area load. Software selectable features include linearisation, ranging, monitoring, testing and tagging for all thermocouple types and 2-, 3- or 4-wire RTDs. (For thermocouple applications the HAZ-CJC plug on terminals 1–3 includes an integral CJC sensor). Configuration is carried out using a personal computer. A single alarm output is provided and may be configured for process alarm or to provide notice of early thermocouple failure.

SPECIFICATION

See also common specification

Number of channels

One

Signal source

THC types J, K, T, E, R, S, B or N to BS 60584 and XK
mV input
RTDs 2/3/4-wire platinum to BS 60751
Pt 100, Pt 500, Pt 1000
Cu-50 & Cu-53
Ni 100/500/1000 DIN 43760

Location of signal source

Zone 0, IIC, T4-6 hazardous area
Division 1, Group A, hazardous location

Input signal range

–75 to +75mV, or 0 to 400Ω (0 to 1000Ω Pt & Ni sensors)

Input signal span

3 to 150mV, or 10 to 400Ω (10 to 1000Ω Pt & Ni sensors)

RTD excitation current

200μA nominal

Cold junction compensation

Automatic or selectable

Cold junction compensation error

≤ 1.0°C

Common mode rejection

120dB for 240V at 50Hz or 60Hz (500ms response)

Series mode rejection

40dB for 50Hz or 60Hz

Calibration accuracy (at 20°C)

(includes hysteresis, non-linearity and repeatability)

Inputs: (500ms response)

mV/THC: ± 15μV or ± 0.05% of input value
(whichever is greater)

RTD: ± 80mΩ

Output: ± 11μA

Temperature drift (typical)

Inputs:

mV/THC: ± 0.003% of input value/°C

RTD: ± 7mΩ/°C

Output: ± 0.6μA/°C

Example of calibration accuracy and temperature drift

(RTD input - 500ms response)

Span:

Accuracy: ± (0.08/250 + 11/16000) × 100%
= 0.1% of span

Temperature drift: ± (0.007/250 × 16000 + 0.6) μA/°C
= ±1.0μA/°C

Safety drive on sensor failure

Upscale, downscale, or off

MTL4575

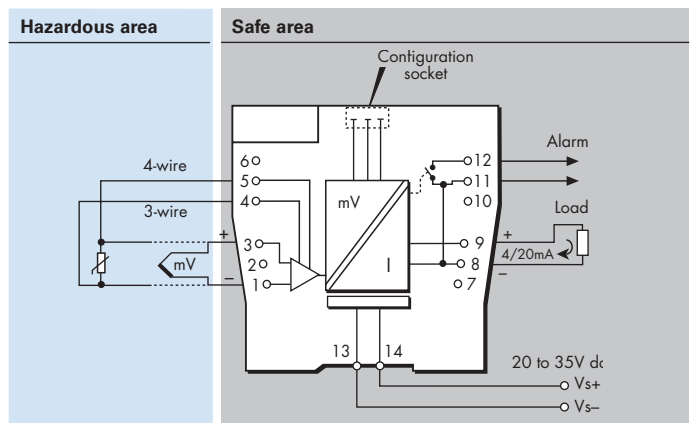

MTL5575

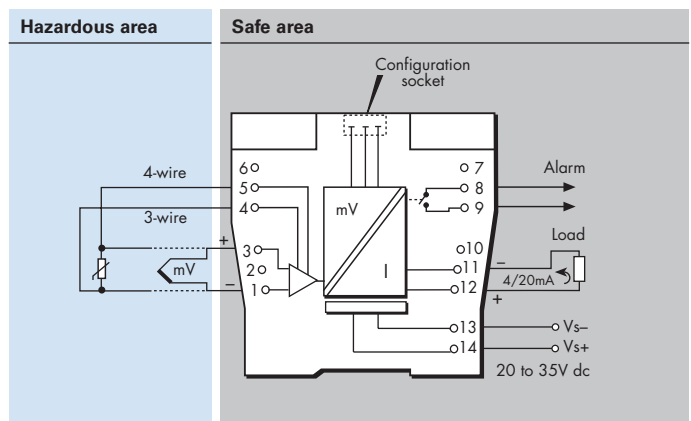

Early burnout

Early burnout detection for thermocouples (when selected)
Alarm trips when loop resistance increase is > 50Ω

Output range

4 to 20mA nominal into 600Ω max.

Alarm output (configurable)

Relay ON in alarm, 250mA @ 35V max

Maximum lead resistance (THC)

600Ω

Response time

Configurable - 500 ms default
(Accuracy at 100/200ms - contact MTL)

LED indicator

Green: power and status indication
Yellow: alarm indication, on when contacts are closed

Maximum current consumption (with 20mA signal)

50mA at 24V

Power dissipation within unit (with 20mA signal)

1.2W at 24V

Safety description

Refer to certificate for parameters. $U_m = 253V$ rms or dc

Configurator

A personal computer running MTL PCS45 software with a PCL45USB serial interface.

The given data is only intended as a product description and should not be regarded as a legal warranty of properties or guarantee. In the interest of further technical developments, we reserve the right to make design changes.



Powering Business Worldwide

Eaton Electric Limited,

Great Marlings, Butterfield, Luton
Beds, LU2 8DL, UK.
Tel: + 44 (0)1582 723633 Fax: + 44 (0)1582 422283
E-mail: mtlenquiry@eaton.com
www.mtl-inst.com

© 2016 Eaton
All Rights Reserved
Publication No.
EPSx575 Rev4 010916

EUROPE (EMEA):

+44 (0)1582 723633 mtlenquiry@eaton.com

THE AMERICAS:

+1 800 835 7075 mtl-us-info@eaton.com

ASIA-PACIFIC:

+65 6 645 9888 sales.mtlsing@eaton.com

MTL4576-RTD – MTL5576-RTD TEMPERATURE CONVERTER

RTD/potentiometer input, 2-channel

The MTLx576-RTD converts signals from resistance temperature detectors (RTDs) mounted in a hazardous area, into 4/20mA currents for driving safe-area loads. Software selectable features include input type and characterisation, ranging, monitoring, testing and tagging. Configuration is carried out using a personal computer. The MTLx576-RTD is compatible with 2- and 3-wire RTD inputs. The MTLx576-RTD can also be configured to drive two safe-area loads from a single input.

SPECIFICATION

See also common specification

Number of channels

Two

Signal source

2-/3-wire RTDs to BS 60751
Pt 100, Pt 500, Pt 1000
Cu-50 & Cu-53
Ni 100/500/1000 DIN 43760

Location of signal source

Zone 0, IIC, T4-6 hazardous area
Division 1, Group A, hazardous location

Input signal range

0 to 400Ω (0 to 4000Ω Pt & Ni sensors)

Input signal span

10 to 400Ω (10 to 1000Ω Pt & Ni sensors)

RTD excitation current

200μA nominal

Common mode rejection

120dB for 240V at 50Hz or 60Hz

Series mode rejection

40dB for 50Hz or 60Hz

Calibration accuracy (at 20°C)

(includes hysteresis, non-linearity and repeatability)

Input: ± 80mΩ

Output: ± 16μA

Temperature drift (typical)

Input: ± 7mΩ/°C

Output: ± 0.6μA/°C

Example of calibration accuracy and temperature drift (RTD input)

Span: 250Ω

Accuracy: ± (0.08/250 + 16/16000) x 100%

= 0.13% of span

Temperature drift: ± (0.007/250 x 16000 + 0.6) μA/°C
= ±1.0μA/°C

Safety drive on sensor failure

Upscale, downscale, or off

Output range

4 to 20mA nominal into 300Ω max.

Response time

Configurable - 500 ms default

(Accuracy at 100/200ms - contact MTL)

MTL4576-RTD

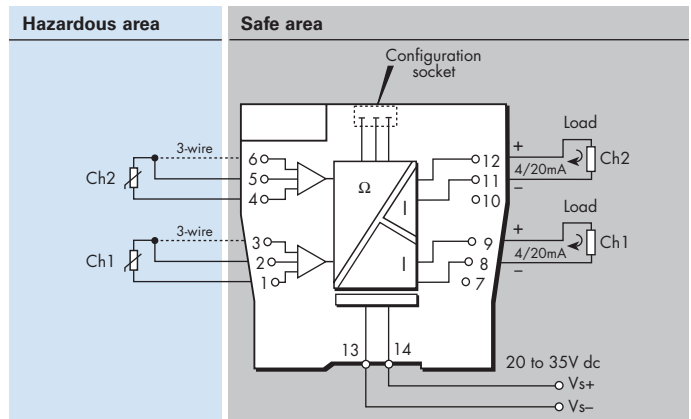

MTL5576-RTD

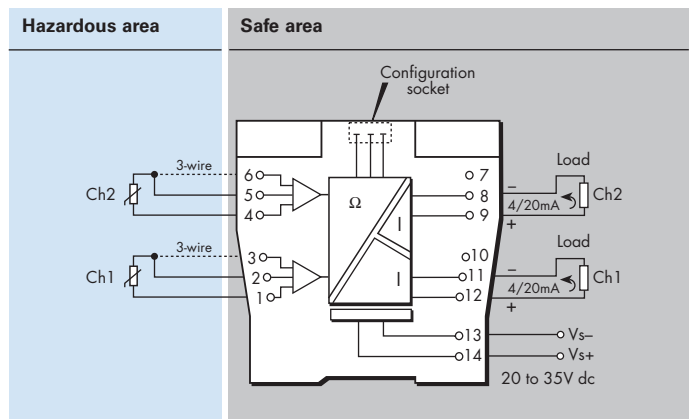

LED indicator

Green: power and status indication
Yellow: one provided for channel status
Red: alarm indication

Power requirement, Vs with 20mA signal

60mA at 24V

Power dissipation within unit with 20mA signal

1.4W at 24V

Isolation

Functional channel-channel isolation for safe and hazardous-area circuits

Safety description

Refer to certificate for parameters. $U_m=253V$ rms or dc

Configurator

A personal computer running MTL PCS45 software with a PCL45USB serial interface.



Powering Business Worldwide

Eaton Electric Limited,

Great Marlings, Butterfield, Luton
Beds, LU2 8DL, UK.
Tel: + 44 (0)1582 723633 Fax: + 44 (0)1582 422283
E-mail: mtlenquiry@eaton.com
www.mtl-inst.com

© 2016 Eaton
All Rights Reserved
Publication No.
EPSx576R Rev5 010916

EUROPE (EMEA):

+44 (0)1582 723633 mtlenquiry@eaton.com

THE AMERICAS:

+1 800 835 7075 mtl-us-info@eaton.com

ASIA-PACIFIC:

+65 6 645 9888 sales.mtlsing@eaton.com

The given data is only intended as a product description and should not be regarded as a legal warranty of properties or guarantee.
In the interest of further technical developments, we reserve the right to make design changes.

MTL4576-THC – MTL5576-THC

TEMPERATURE CONVERTER

mV/THC input, 2-channel

The MTLx576-THC converts low-level dc signals from temperature sensors mounted in a hazardous-area into 4/20mA currents for driving safe-area loads. Software selectable features include linearisation for standard thermocouple types, ranging, monitoring, testing and tagging. Configuration is carried out using a personal computer. The hazardous-area connections include cold-junction compensation and do not need to be ordered separately.

SPECIFICATION

See also common specification

Number of channels

Two

Signal source

THC types J, K, T, E, R, S, B or N to BS 60584 and XK mV input

Location of signal source

Zone 0, IIC, T4-6 hazardous area
Division 1, Group A, hazardous location

Input signal range

-75 to +75mV

Input signal span

3 to 150mV

Cold junction compensation

Automatic or selectable

Cold junction compensation error

≤ 1.0°C

Common mode rejection

120dB for 240V at 50Hz or 60Hz

Series mode rejection

40dB for 50Hz or 60Hz

Calibration accuracy (at 20°C)

(includes hysteresis, non-linearity and repeatability)

Input: ±15µV or ±0.05% of input value
(whichever is greater)

Output: ±16µA

Temperature drift (typical)

Input: ±0.003% of input value/°C

Output: ±0.6µA/°C

Safety drive on sensor burnout

Upscale, downscale, or off

Output range

4 to 20mA nominal into 300Ω max.

Maximum lead resistance

300Ω

Response time

Configurable - 500 ms default

(Accuracy at 100/200ms - contact Eaton's MTL product line)

MTL4576-THC

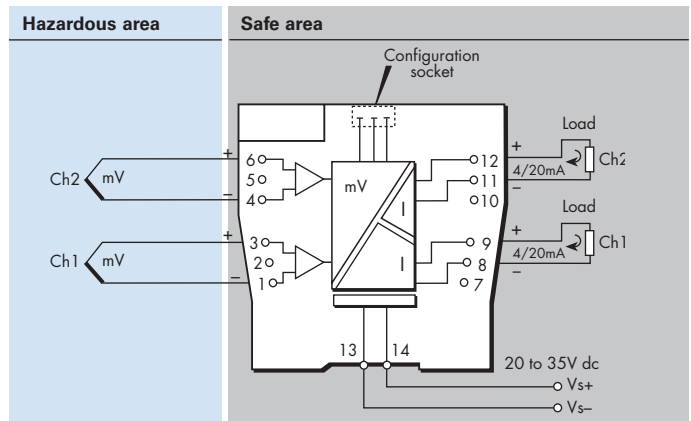

MTL5576-THC

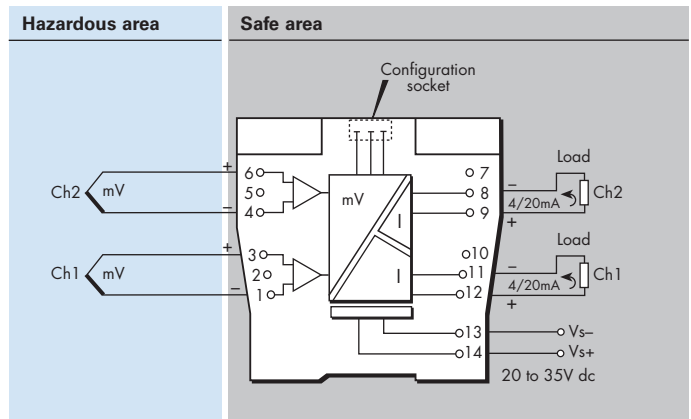

LED indicator

Green: power and status indication
Yellow: one provided for channel status
Red: alarm indication

Power requirement, Vs with 20mA signal

60mA at 24V

Power dissipation within unit with 20mA signal

1.4W at 24V

Isolation

Functional isolation channel-channel for safe and hazardous-area circuits.

Safety description

Refer to certificate for parameters. Um=253V rms or dc

Configurator

A personal computer running MTL PCS45 software with a PCL45USB serial interface.

The given data is only intended as a product description and should not be regarded as a legal warranty of properties or guarantee. In the interest of further technical developments, we reserve the right to make design changes.



Powering Business Worldwide

Eaton Electric Limited,
Great Marlings, Butterfield, Luton
Beds, LU2 8DL, UK.
Tel: + 44 (0)1582 723633 Fax: + 44 (0)1582 422283
E-mail: mtlenquiry@eaton.com
www.mtl-inst.com

© 2016 Eaton
All Rights Reserved
Publication No.
EPSx576T Rev4 010916

EUROPE (EMEA):
+44 (0)1582 723633 mtlenquiry@eaton.com
THE AMERICAS:
+1 800 835 7075 mtl-us-info@eaton.com
ASIA-PACIFIC:
+65 6 645 9888 sales.mtlsing@eaton.com

MTL4581 – MTL5581 MILLIVOLT/THERMOCOUPLE ISOLATOR

for low-level signals

The MTLx581 takes a low-level dc signal from a voltage source in a hazardous area, isolates it, and passes it to a receiving instrument located in the safe area. The module is intended for use with thermocouples utilising external cold-junction compensation. A switch enables or disables the safety drive in the event of thermocouple burnout or cable breakage; a second switch permits the selection of upscale or downscale operation as appropriate.

SPECIFICATION

See also common specification

Number of channels

One

Signal source

Any dc millivolt source

Location of millivolt source

Zone 0, IIC, T4–T6 hazardous area if suitably certified
Div. 1, Group A, hazardous location

Input and output signal range

0 to ± 50 mV, overrange to ± 55 mV
Maximum lead resistance 600 Ω

Output resistance

60 Ω nominal

Transfer accuracy@20°C

Linearity and repeatability < 0.05% of reading or $\pm 5\mu$ V,
whichever is the greater

Temperature drift

< 2 μ V/°C, maximum

Response time

Settles to within 10% of final value within 150 μ s

Frequency response

dc to 4kHz nominal

Safety drive on THC burnout

Two switches enable or disable the safety drive and select
upscale or downscale operation

MTL4581

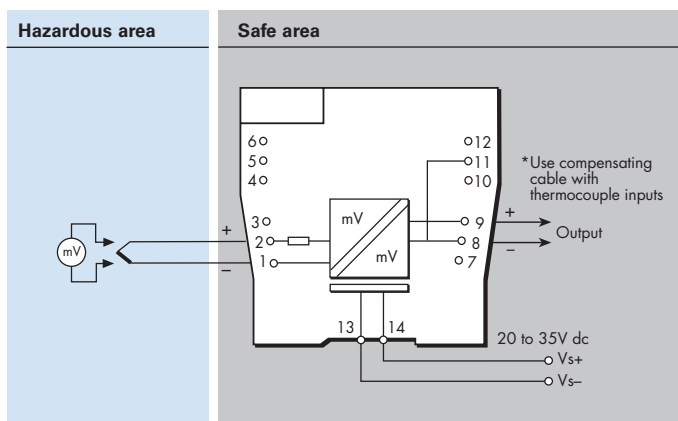

MTL5581

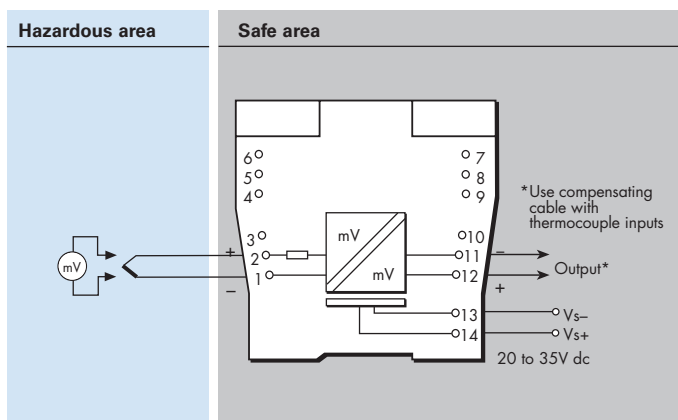

LED indicator

Green: power indication

Power requirement, Vs

30mA max, 20V dc to 35V dc

Power dissipation within unit

0.7W typical at 24V
0.91W at 35V

Safety description

Terminals 1 to 2

Non-energy-storing apparatus ≤ 1.5 V, ≤ 0.1 A and ≤ 25 mW; can be connected without further certification into any IS loop with an open-circuit voltage <28V



Powering Business Worldwide

Eaton Electric Limited,

Great Marlings, Butterfield, Luton
Beds, LU2 8DL, UK.
Tel: + 44 (0)1582 723633 Fax: + 44 (0)1582 422283
E-mail: mtlenquiry@eaton.com
www.mtl-inst.com

© 2016 Eaton
All Rights Reserved
Publication No.
EPSx581 Rev4 010916

EUROPE (EMEA):

+44 (0)1582 723633 mtlenquiry@eaton.com

THE AMERICAS:

+1 800 835 7075 mtl-us-info@eaton.com

ASIA-PACIFIC:

+65 6 645 9888 sales.mtlsing@eaton.com

The given data is only intended as a product description and should not be regarded as a legal warranty of properties or guarantee.

In the interest of further technical developments, we reserve the right to make design changes.

MTL5582

RESISTANCE ISOLATOR

to repeat RTD signals

The MTL5582 connects to a 2-, 3-, or 4-wire resistance temperature device (RTD) or other resistance located in a hazardous area, isolates it and repeats the resistance to a monitoring system in the safe area. The module is intended typically (but not exclusively) for use with Pt100 3-wire RTDs. Switches enable selection of 2-, 3-, or 4-wire RTD connection. The MTL5582 should be considered as an alternative, non-configurable MTL5575, for use in RTD applications where a resistance input is preferred or needed instead of 4/20mA. The design is notable for its ease of use and repeatability. The number of wires which can be connected on the safe-area side of the unit is independent of the number of wires which can be connected on the hazardous-area side. The module drives upscale in the case of open circuit detection. Note that this module is not suitable for use with measurement systems where the resistance input channels are multiplexed.

SPECIFICATION

See also common specification

Number of channels

One

Location of RTD

Zone 0, IIC, T4 hazardous area
Div. 1, Group A, hazardous location

Resistance source

2-, 3-, or 4-wire* RTDs to BS 1904/DIN 43760 (100Ω at 0°C)
*user selectable by switches (factory set for 3-wire)

Resistance range

10Ω to 400Ω

RTD excitation current

200μA nominal

Output configuration

2, 3 or 4 wires (independent of mode selected for hazardous area terminals)

Output range

10Ω to 400Ω (from a 100μA to 5mA source)

Temperature drift

±10mΩ/°C typical (0.01%/°C @ 100Ω)

Response time

To within 4% of final value within 1s
Not suitable for multiplexed input cards

Safety drive on open-circuit sensor

Upscale to 420Ω nominal

Transfer accuracy@20°C

<0.15Ω at excitation current 1 - 5mA
<0.25Ω at excitation current 0.5 - 1mA



MTL5582

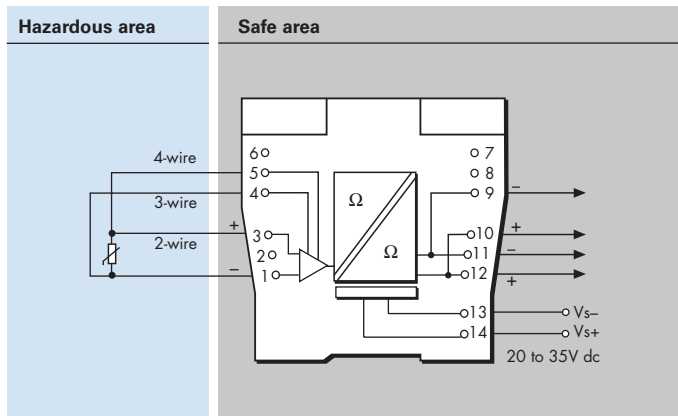

LED indicator

Green: power indication

Power requirements, V_s

33mA at 24V
35mA at 20V
28mA at 35V

Maximum power dissipation within unit

0.8W at 24V
1.0W at 35V

Safety description

Terminals 1 and 3

U_o = 1.2V I_o = 4mA P_o = 1.2mW U_m = 253V rms or dc
Non-energy-storing apparatus ≤ 1.5V, ≤ 0.1A, ≤ 25mW; can be connected without further certification into any IS loop with an open circuit voltage < 5V.

Terminals 1 and 3 and 4 and 5

U_o = 6.6V I_o = 42mA P_o = 69mW



SIL capable

These models have been assessed for use in IEC 61508 functional safety applications.

SIL1 capable for a single device (HFT=0)
SIL2 capable for multiple devices in safety redundant configuration (HFT=1)

See data on MTL web site and refer to the safety manual.

NOTE: The MTL5582 is due to be superseded by the MTL5582B during Q3 2016.



Powering Business Worldwide

Eaton Electric Limited,

Great Marlings, Butterfield, Luton
Beds, LU2 8DL, UK.
Tel: + 44 (0)1582 723633 Fax: + 44 (0)1582 422283
E-mail: mtlenquiry@eaton.com
www.mtl-inst.com

© 2016 Eaton
All Rights Reserved
Publication No.
EPS5582 Rev5 010916

EUROPE (EMEA):

+44 (0)1582 723633 mtlenquiry@eaton.com

THE AMERICAS:

+1 800 835 7075 mtl-us-info@eaton.com

ASIA-PACIFIC:

+65 6 645 9888 sales.mtlsing@eaton.com

The given data is only intended as a product description and should not be regarded as a legal warranty of properties or guarantee. In the interest of further technical developments, we reserve the right to make design changes.

MTL4582B - MTL5582B RESISTANCE ISOLATOR

to repeat RTD signals

The MTLx582B connects to a 2-, 3-, or 4-wire resistance temperature device (RTD) or other resistance located in a hazardous area, isolates it and repeats the resistance to a monitoring system in the safe area. The module is intended typically (but not exclusively) for use with Pt100 3-wire RTDs. Switches enable selection of 2-, 3-, or 4-wire RTD connection. The MTLx582B should be considered as an alternative, non-configurable MTLx575, for use in RTD applications where a resistance input is preferred or needed instead of 4/20mA. The design is notable for its ease of use and repeatability. The number of wires which can be connected on the safe-area side of the unit is independent of the number of wires which can be connected on the hazardous-area side. The module drives upscale in the case of open circuit detection.

SPECIFICATION

See also common specification

Number of channels

One

Location of RTD

Zone 0, IIC, T4 hazardous area
Div. 1, Group A, hazardous location

Resistance source

2-, 3-, or 4-wire* RTDs to BS 1904/DIN 43760 (100 Ω at 0°C)
*user selectable by switches (factory set for 3-wire)

Resistance range

10 Ω to 400 Ω

RTD excitation current

200 μ A nominal

Output configuration

2, 3 or 4 wires (independent of mode selected for hazardous area terminals)

Output range

10 Ω to 400 Ω (from a 100 μ A to 5mA source)

Temperature drift

± 10 m Ω /°C typical (0.01%/°C @ 100 Ω)

Response time

To within 4% of final value within 1s

Safety drive on open-circuit sensor

Upscale to 420 Ω nominal

Transfer accuracy@20°C

<0.15 Ω at excitation current 1 - 5mA
<0.25 Ω at excitation current 0.5 - 1mA

MTL4582B

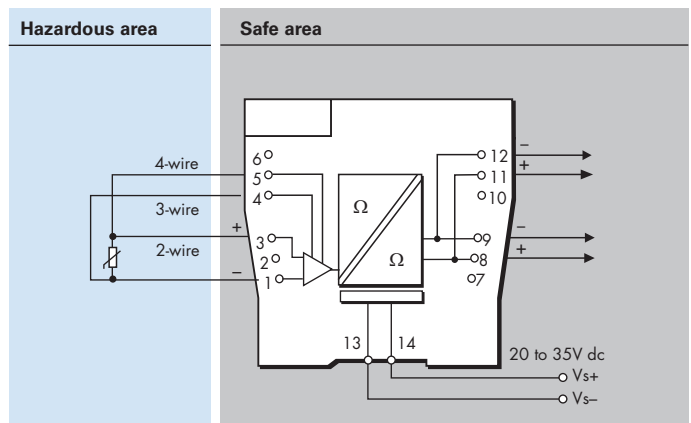

MTL5582B

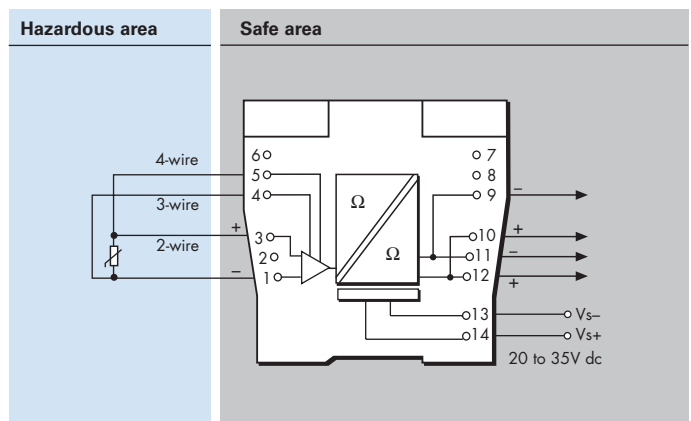

LED indicator

Green: power indication

Power requirements, Vs

33mA at 24V
35mA at 20V
28mA at 35V

Maximum power dissipation within unit

0.8W at 24V
1.0W at 35V

Safety description

Terminals 1 and 3

$U_o = 1.2$ V $I_o = 4$ mA $P_o = 1.2$ mW $U_m = 253$ V rms or dc

Non-energy-storing apparatus ≤ 1.5 V, ≤ 0.1 A, ≤ 25 mW; can be connected without further certification into any IS loop with an open circuit voltage < 5V.

Terminals 1, 3, 4 and 5

$U_o = 6.51$ V $I_o = 10$ mA $P_o = 17$ mW



Powering Business Worldwide

Eaton Electric Limited,

Great Marlings, Butterfield, Luton
Beds, LU2 8DL, UK.
Tel: + 44 (0)1582 723633 Fax: + 44 (0)1582 422283
E-mail: mtlenquiry@eaton.com
www.mtl-inst.com

© 2016 Eaton
All Rights Reserved
Publication No.
EPSx582B Rev3 010916

EUROPE (EMEA):

+44 (0)1582 723633 mtlenquiry@eaton.com

THE AMERICAS:

+1 800 835 7075 mtl-us-info@eaton.com

ASIA-PACIFIC:

+65 6 645 9888 sales.mtlsing@eaton.com

The given data is only intended as a product description and should not be regarded as a legal warranty of properties or guarantee.

In the interest of further technical developments, we reserve the right to make design changes.

MTL4599 - MTL5599 DUMMY ISOLATOR

The primary function of the MTLx599, which can be used with all other MTLx500 range of units, is to provide termination and earthing facilities for unused cable cores from hazardous areas.

SPECIFICATION

See also common specification

Weight
60g

MTL4599

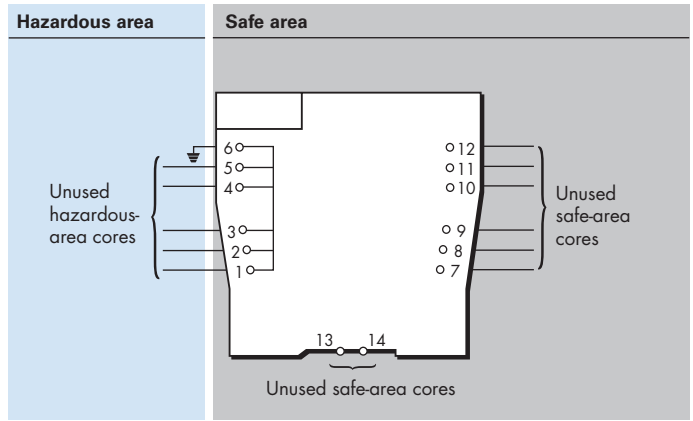

MTL5599

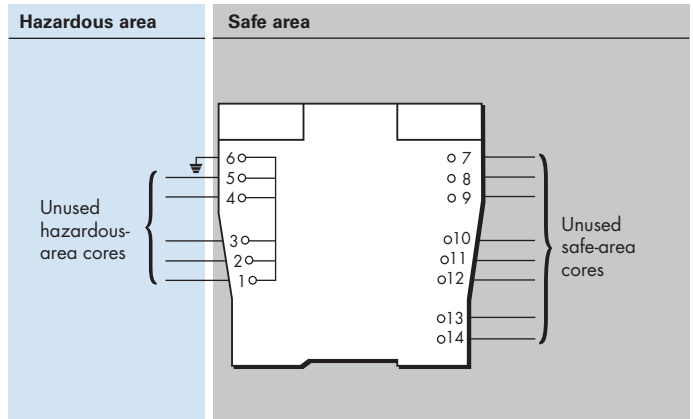

MTL4599N GENERAL PURPOSE FEED-THROUGH MODULE

The feed-through termination module allows non-IS connections to the MTL4500 backplanes. The wires from the field are connected using screw terminals. Six terminals are provided on top of the module and linked down to the multiway connector on the backplane. The terminals and cables conform to IS regulations so that non-IS and IS signals can be mixed on the same backplane.

Note: Must not be used with signals >50V or >0.25A

SPECIFICATION

See also common specification

Weight
60g

MTL4599N

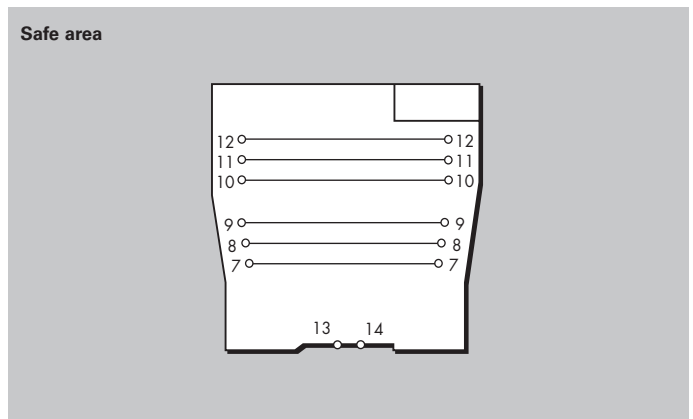

Powering Business Worldwide

Eaton Electric Limited,
Great Marlings, Butterfield, Luton
Beds, LU2 8DL, UK.
Tel: + 44 (0)1582 723633 Fax: + 44 (0)1582 422283
E-mail: mtlenquiry@eaton.com
www.mtl-inst.com

© 2016 Eaton
All Rights Reserved
Publication No.
EPSx599/N Rev4 010916

EUROPE (EMEA):
+44 (0)1582 723633 mtlenquiry@eaton.com
THE AMERICAS:
+1 800 835 7075 mtl-us-info@eaton.com
ASIA-PACIFIC:
+65 6 645 9888 sales.mtlsing@eaton.com

The given data is only intended as a product description and should not be regarded as a legal warranty of properties or guarantee. In the interest of further technical developments, we reserve the right to make design changes.

MTL4500 - MTL5500 RANGE COMMON SPECIFICATIONS

Please go to our website at www.mtl-inst.com for the latest information regarding safety approvals, certificates and entity parameters.

Connectors

Each unit is supplied with signal connectors, as applicable. When using crimp ferrules for the hazardous or non-hazardous (safe) signal connectors the metal tube length should be 12mm and the wire trim length 14mm.

Isolation

250V rms, tested at 1500V rms minimum, between safe- and hazardous-area terminals.

MTL4500: 50V between safe-area circuits and power supply

MTL5500: 250V rms between safe-area circuits and power supply

Supply voltage

20 – 35V dc

Location of units

Safe area

Terminals

Accepts conductors of up to 2.5mm² stranded or single-core

Mounting

MTL4500

MTL4500 range of backplanes

MTL5500

T-section 35mm DIN rail (7.5 or 15mm) to EN 50022

Ambient temperature limits

-20 to +60°C (-6 to +140°F) operating

-40 to +80°C (-40 to +176°F) storage

Humidity

5 to 95% relative humidity

Weight

Approximate (except where indicated)

MTL4500 140g

MTL5500 150g

EMC

To EN61326 and NE21*

* For 20ms power interruption compliance, a suitable power supply must be used.

HART® is a registered trademark of HART Communication Foundation

DIMENSIONS (MM)

MTL4500

Optional TH5000 tag holder for individual isolator identification. Accepts tag label 25 x 12.5 ±0.5mm, 0.2mm thick

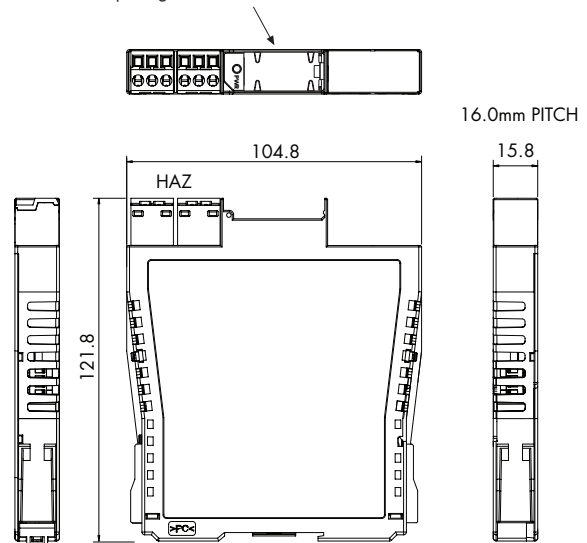

MTL5500

Optional TH5000 tag holder for individual isolator identification. Accepts tag label 25 x 12.5 ±0.5mm, 0.2mm thick

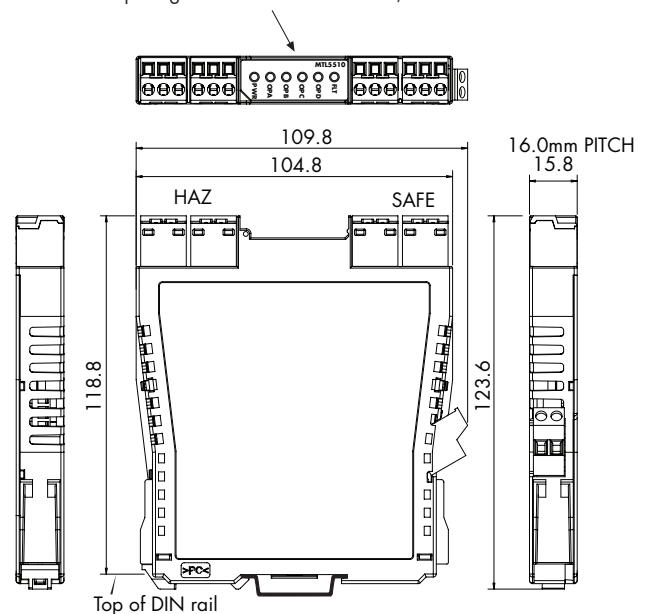

The given data is only intended as a product description and should not be regarded as a legal warranty of properties or guarantee. In the interest of further technical developments, we reserve the right to make design changes.



Powering Business Worldwide

Eaton Electric Limited,

Great Marlings, Butterfield, Luton
Beds, LU2 8DL, UK.
Tel: + 44 (0)1582 723633 Fax: + 44 (0)1582 422283
E-mail: mtlenquiry@eaton.com
www.mtl-inst.com

© 2016 Eaton
All Rights Reserved
Publication No.
EPSx5CS Rev4 010916

EUROPE (EMEA):

+44 (0)1582 723633 mtlenquiry@eaton.com

THE AMERICAS:

+1 800 835 7075 mtl-us-info@eaton.com

ASIA-PACIFIC:

+65 6 645 9888 sales.mtlsing@eaton.com

MPA5500 A.C. POWER ADAPTOR

The MPA5500 enables any MTL5500 module that is normally powered from a nominal 24V DC supply (i.e. those that are not loop-powered) to be powered from a high-voltage AC supply.

It plugs into the power socket (terminals 13 and 14) of an MTL5500 module and clips securely onto the module housing. The 25V DC power output from the adaptor is sufficient to supply a single module and can be connected to any normal AC power source.

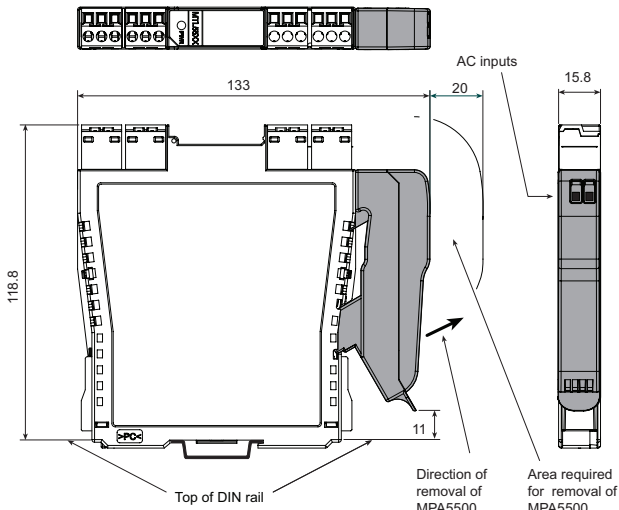

SPECIFICATION

Input voltage

85 – 265V AC, (45–65Hz)

Efficiency

71% typ. at 230V AC

Power dissipation

1.2W typ at 230V AC.

Input terminals

Cage-clamp terminals accommodating conductors up to 1.5mm² stranded or 16AWG single-core

Input protection

internal fuse, not user serviceable

Output voltage

25Vdc ± 10%

Output current

120mA at 25V

Ambient temperature

Operating: –20 to +60°C

Storage: –40 to +80°C

Mounting

Plugs into and clips onto MTL5500 range I/O module
It is not for use with any equipment other than MTL5500.

Humidity

5 to 95% relative humidity

Mechanical

Ingress Protection: IP20
Material: polycarbonate
Weight: 28g approx.

Standards compliance

EN 61326, EN 61010

PCS45/PCL45USB CONFIGURATOR FOR MTL CONVERTERS

The PCS45/PCL45USB configurator allows MTL converters to be configured from a standard PC running a Microsoft® Windows® operating system. It comprises PC software, provided on a CD (PCS45), and an ATEX certified interfacing link (PCL45USB). Converters can be configured from the safe area, while on-line, and configurations can be saved to disk and printed out when required. It is suitable for use with MTL4000, MTL4500, MTL5000 and MTL5500 range of products.

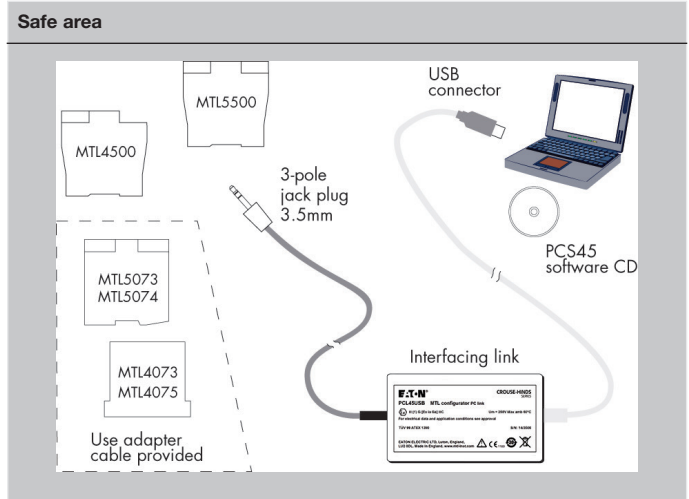

SPECIFICATION

PCL45USB hardware

Location

Safe area

Connections

PC side: USB B(F) socket

Converter side: cable with 3.5mm jackplug, 3-pole for MTL4500 and MTL5500 range of converters. An adapter cable is provided for other earlier MTL converters.

Cable lengths

Converter side (fitted): 1.5m

USB cable A(M) to B(M) (supplied): 2m

Ambient temperature limits

–10°C to +60°C operating

–20°C to +70°C storage

Humidity

5 to 95% relative humidity (non-condensing)

Weight

200g

PCS45 Configuration software

Compatible with Windows XP, Win7, Win8.

Consult MTL for operation with any other operating system.

Software medium

PCS45 supplied on CD

Updates are available at www.mtl-inst.com

Recommended minimum PC configuration

Microsoft Windows XP, Win7, Win8

20MB of available hard disc space

CD ROM drive

Available USB port

Printer (local or network)

The given data is only intended as a product description and should not be regarded as a legal warranty of properties or guarantee.
In the interest of further technical developments, we reserve the right to make design changes.



Powering Business Worldwide

Eaton Electric Limited,

Great Marlings, Butterfield, Luton
Beds, LU2 8DL, UK.
Tel: + 44 (0)1582 723633 Fax: + 44 (0)1582 422283
E-mail: mtlenquiry@eaton.com
www.mtl-inst.com

© 2016 Eaton
All Rights Reserved
Publication No.
EPS45/5500 Rev5 010916

EUROPE (EMEA):

+44 (0)1582 723633 mtlenquiry@eaton.com

THE AMERICAS:

+1 800 835 7075 mtl-us-info@eaton.com

ASIA-PACIFIC:

+65 6 645 9888 sales.mtling@eaton.com

MTL5991 24V DC POWER SUPPLY

A DIN-rail mounted unit for locations where a dc supply is not readily available. The wide input power supply range makes this unit universally applicable and the 24V dc , 2A output will drive a useful number of MTL5000 and MTL5500 range of modules.

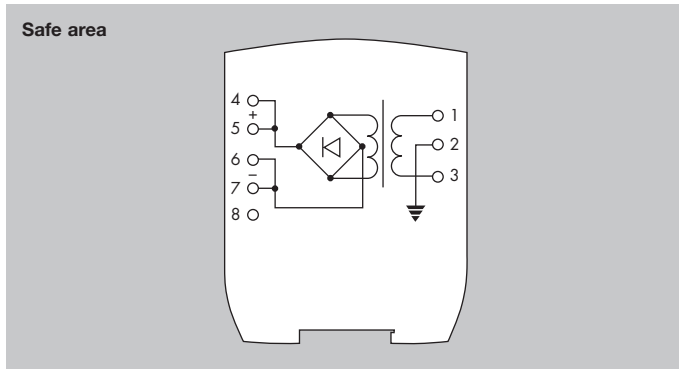

SPECIFICATION

Power supply

85 to 264V ac 47 to 63Hz

Power dissipation within unit

7.2W @ 2A

Mounting

35mm DIN (top hat) rail

Output voltage

24V dc nom (23.64 min/24.36 max)

Output current

2A maximum (1.7A with <105V ac input)

LED indicators

Green: Power indication

Weight

310g

Ambient temperature

Operating temperature -10°C to +50°C

Storage temperature -40°C to +85°C

Terminals

Cage clamp type accommodating conductors up to 2.5mm², stranded or single-core

Note: Segregation between hazardous and safe area wiring must be maintained.

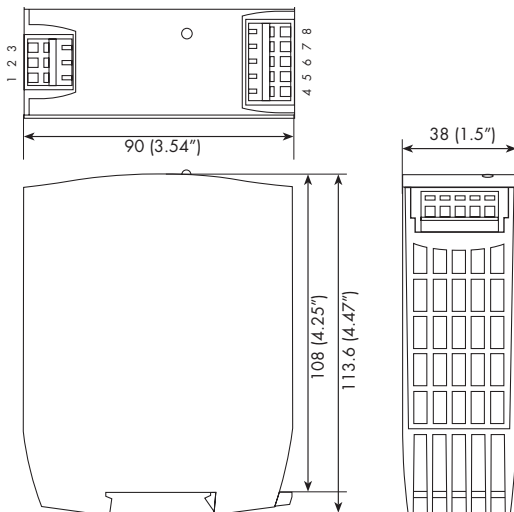

MTL5500 RANGE POWERBUS KITS PB - 8T,16T,24T,32T

A quick and easy way to distribute DC power to MTL5500 range modules. Each powerbus kit includes 4 single ferrules, 4 twin ferrules and 2 insulation displacement connectors (Scotchlok).

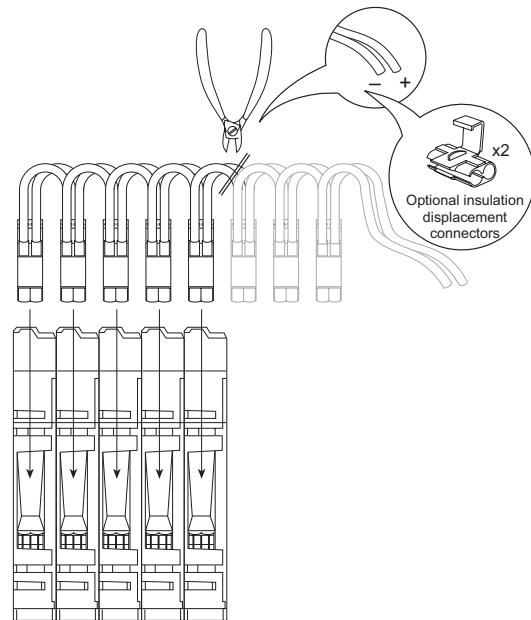

SPECIFICATION

Available in 4 different lengths:

| | |
|----------|---------------------------|
| PB - 8T | = 8 connectors and loops |
| PB - 16T | = 16 connectors and loops |
| PB - 24T | = 24 connectors and loops |
| PB - 32T | = 32 connectors and loops |

Insulation material :

PVC

Conductor :

24 strands of 0.2mm dia (0.75mm²) standard copper

Insulation thickness :

0.5 to 0.8 mm

Current rating :

12A max

Operating temperature range :

-20°C to +60°C

Max voltage drop on 32 modules drawing 130mA max :

0.5V

CHOOSING A POWERBUS KIT

Choose a powerbus where the number of power plugs is greater than or equal to the number of isolators to be powered and if necessary cut the powerbus to the required number of terminations.

Note: To reduce the risk of excessive voltage drop or overcurrent do not connect powerbuses in series.



Powering Business Worldwide

Eaton Electric Limited,

Great Marlings, Butterfield, Luton
Beds, LU2 8DL, UK.
Tel: + 44 (0)1582 723633 Fax: + 44 (0)1582 422283
E-mail: mtlenquiry@eaton.com
www.mtl-inst.com

© 2016 Eaton
All Rights Reserved
Publication No.
EPS45/5500 Rev4 010916

EUROPE (EMEA):

+44 (0)1582 723633 mtlenquiry@eaton.com

THE AMERICAS:

+1 800 835 7075 mt-us-info@eaton.com

ASIA-PACIFIC:

+65 6 645 9888 sales.mtlsing@eaton.com

MTL5500 RANGE ENCLOSURES

DIMENSIONS (mm) AND MOUNTING

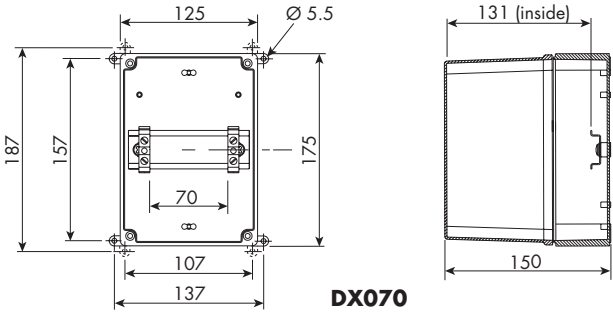

DX070

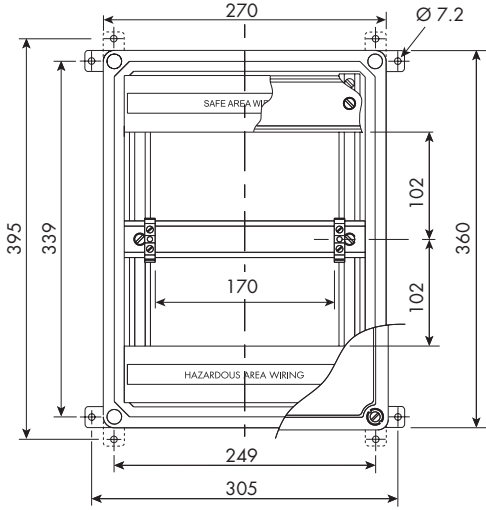

DX170

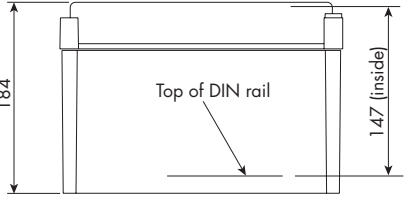

SPECIFICATION

Construction

- Glass reinforced polycarbonate base - DX070
- Glass reinforced polyester base - DX170
- Transparent polycarbonate lid

Protection

- Dust-tight and water-jet proof to IEC529:IP65

Lid fixing

- Captive fixing screws

Weight (excluding barriers/isolators) kg

- DX070 0.8
- DX170 2.6

Items provided

- DIN rail - fitted
- ETL7000 Earth terminals (2 x) - fitted
- "Take care IS" front adhesive label
- Cable trunking (DX170 only)

Note: Isolators are not included.

Mounting

- Wall fixing lugs provided. For further details refer to INM5500.

Tagging and earth rail

- Accommodates MTL5500 range of accessories.

Permitted location

- Safe (non-hazardous) area

Note: N. America/Canada - Enclosures are rated NEMA 4X so can be used in Class 1, Division 2 (gases) location, but check with local requirements and ensure all cable entries also conform. Additional warning label will be required on or near the enclosure, see installation details. Not suitable for Class II or III, Division 2 hazardous locations.

Approximate capacities (on DIN rail between earth terminals)

| | Number of MTL5500 isolators | |
|--------------|-----------------------------|------|
| DX070 | 4 | (2)* |
| DX170 | 10 | (8)* |

* Use these figures when IMB57 mounting blocks for tagging/earth are included.

Ambient temperature limits

Dependent on units fitted. See instruction manual INM5500.



Eaton Electric Limited,
Great Marlings, Butterfield, Luton
Beds, LU2 8DL, UK.
Tel: + 44 (0)1582 723633 Fax: + 44 (0)1582 422283
E-mail: mtlenquiry@eaton.com
www.mtl-inst.com

© 2016 Eaton
All Rights Reserved
Publication No.
EPS45/5500 Rev5 010916

EUROPE (EMEA):
+44 (0)1582 723633 mtlenquiry@eaton.com
THE AMERICAS:
+1 800 835 7075 mtl-us-info@eaton.com
ASIA-PACIFIC:
+65 6 645 9888 sales.mtlsing@eaton.com

The given data is only intended as a product description and should not be regarded as a legal warranty of properties or guarantee. In the interest of further technical developments, we reserve the right to make design changes.

MTL5500 RANGE ACCESSORIES

MTL5500 range of isolators mount quickly and easily onto standard DIN rail. A comprehensive range of accessories simplifies earthing and tagging arrangements.

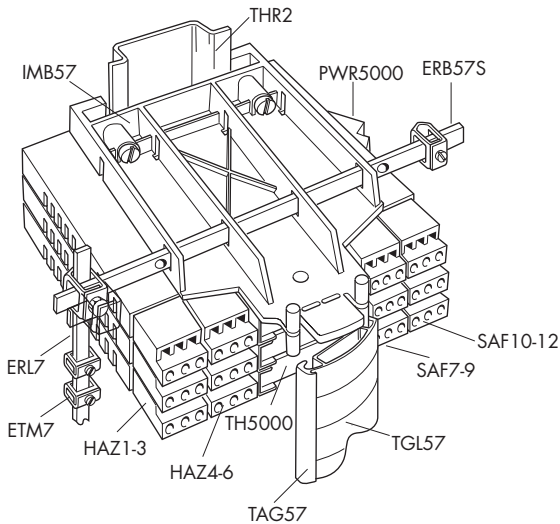

MOUNTING

THR2 DIN rail, 1m length

DIN rail to EN50022; BS5584; DIN46277

MS010 DIN rail module spacer, 10mm, pack of 5

Grey spacer, one required between each MTL5533 or MTL5995-PS and any adjacent module on a DIN rail, to provide 10mm air-circulation space between modules

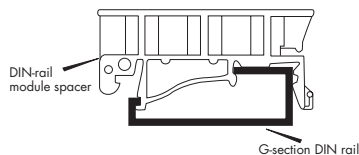

EARTH RAILS AND TAG STRIP

IMB57 Insulating mounting block

One required at each end of a tagging strip/earth rail. Suitable for low-profile (7.5mm) and high-profile (15mm) symmetrical DIN rail.

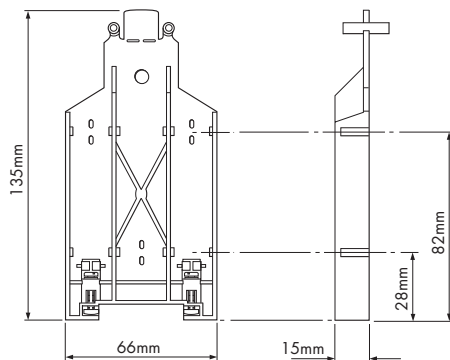

ERB57S Earth-rail bracket, straight

Nickel-plated; supplied with two push fasteners, one (14mm, 35mm²) earth-rail clamp and one (10mm, 16mm²) earth clamp.

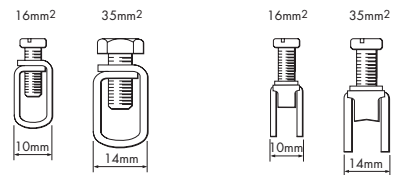
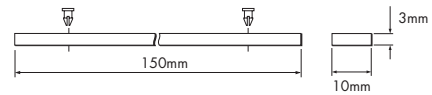

ERL7 Earth rail, 1m length

Nickel-plated; may be cut to length.



ETM7 Earth terminal, bag of 50

For terminating cable screens and 0V returns on the ERL7 earth rail. For cables ≤ 4mm². Exact dimension dependent on manufacturer.

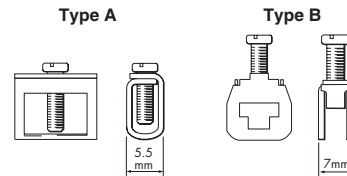

TAG57 Tagging strip, 1m length

Cut to size. Supplied with tagging strip label suitable for MTL5000 or MTL5500 modules.



TGL57 Tagging strip labels, set of 10 x 0.5m

Spares replacement, for use with TAG57 tagging strip. Suitable for MTL5000 or MTL5500 modules.

INDIVIDUAL ISOLATOR IDENTIFICATION

TH5000 tag holders

Each isolator may be fitted with a clear plastic tag holder, as shown below. Order TH5000, pack of 20.

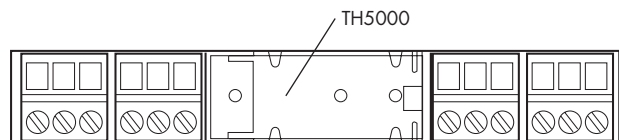

CONNECTORS

Each MTL5500 unit is supplied with signal and power connectors, as applicable.

Spares replacement connectors are available separately; see ordering information.

See also
'MTL5500 range of powerbus kits'

The given data is only intended as a product description and should not be regarded as a legal warranty of properties or guarantee. In the interest of further technical developments, we reserve the right to make design changes.

CUSTOM, STANDARD AND UNIVERSAL BACKPLANES FOR EASY DCS INTEGRATION

- Total flexibility
- Reduce wiring
- Simplify installation
- Special functions
- Signal conditioning
- HART® integration

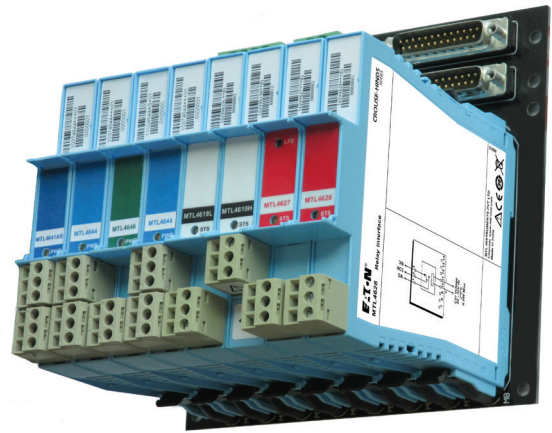

The MTL4500/MTL4600 range of backplanes, enclosures and other accessories provide comprehensive, flexible and remarkably compact mounting facilities for system vendors, original equipment manufacturers and end users alike.

CUSTOMISED BACKPLANES

Eaton provides a complete design and manufacturing service for MTL customised backplanes. Customised backplanes give the vendors and users of process control and safety systems the opportunity to integrate MTL4500/MTL4600/HART® modules directly into their system architecture. As there are no hazardous-area circuits on the backplanes, customised versions can be produced without the need for IS certification, so simplifying design and lowering costs.

UNIVERSAL CUSTOM BACKPLANES

The 'universal' backplane allows a fast and economic approach to providing a custom interface. Where tight time schedules exist, the backplane can be installed to allow the panel building and wiring to be completed. The customised adapter card can then be plugged in at any time up to integrated test.

ADAPTER CARDS

Adapter cards already exist for many of the DCS companies. In addition there is a range of general purpose cards that offer reduced wiring for use with specific MTL modules. These are also available in left- and right-hand versions to ease panel wiring.

STANDARD MTL BACKPLANES

Standard MTL backplanes are available to accommodate 4, 8, 16, or 24 modules using screw-clamp connectors for the safe-area circuits. On an individual backplane, any module can be plugged into any position and module types can be mixed. For 8-, 16- and 24-way backplanes, screw-clamp connectors which plug into the backplanes provide primary and secondary 24V dc power supplies. Power to several 8- or 16-way backplanes can be interconnected to reduce and simplify wiring – see instruction manual INM4500/INM4600 for details.

MTL CPS STANDARD BACKPLANES

| Backplane model no. | Number of modules | Safe-area connections | MOUNTING KITS | | | ACCESSORIES | | |
|---------------------|-------------------|-----------------------|---------------|-------------------|--------------|----------------|-------------------|--------------------------------|
| | | | Surface | DIN-rail (T or G) | 19-inch rack | Earth-rail kit | Tagging strip kit | Spare fuse pack |
| CPS04 | 4 | Screw-clamp | SMS01 | DMK01 | – | – | – | FUS1.0ATE5 |
| CPS08 | 8 | Screw-clamp | SMS01 | DMK01 | – | ERK08 | TSK08 | FUS1.0ATE5 |
| CPS16 | 16 | Screw-clamp | SMS01 | DMK01 | – | ERK16 | TSK16 | FUS2.0ATE5 or FUS2.5ATE5 |
| CPS24 | 24 | Screw-clamp | SMS01 | DMK01 | HMP24 | – | TSK24 | FUS4.0ATE5 |

OPTIONAL ACCESSORIES

Optional accessories include colour coded tagging strip kits for all three sizes of backplane and earth rail kits for 8 and 16-way versions. Mounting accessories are available for surface (all backplanes), T-section and G-section DIN-rail (8- and 16-way versions), and a horizontal plate for mounting 24-way backplanes in 19-inch racks.

WEATHERPROOF ENCLOSURES

Weatherproof enclosures are available for applications where separate safe-area enclosures are required for backplanes with modules. Available to accommodate one 4-way or one 8-way backplane, they are manufactured from GRP giving protection against dust and water to IEC529:IP65. The lids are made from transparent high-strength polycarbonate so that LEDs, switches, etc, on the tops of the modules are easy to see.

DCS VENDORS/SYSTEMS SUPPORTED:

ABB Automation

S100, INFI90, S800

Emerson

Delta V, M Series, S Series

GE Bently-Nevada

HIMA

HIMax

Honeywell

PMIO, C200, C300, UPIO, Safety Manager, USIO

Rockwell Automation

ICS Triplex, Plantguard

Schneider Electric

Foxboro I/A, Triconex Trident/Tricon, Modicon

Siemens

ET200, S7

Yokogawa

Centum R3, VP, Prosafe RS, CS3000



Powering Business Worldwide

Eaton Electric Limited,

Great Marlings, Butterfield, Luton Beds, LU2 8DL, UK.
Tel: + 44 (0)1582 723633 Fax: + 44 (0)1582 422283
E-mail: mtlenquiry@eaton.com
www.mtl-inst.com

© 2016 Eaton
All Rights Reserved
Publication No.
EPS45/5500 Rev6 010916

EUROPE (EMEA):

+44 (0)1582 723633 mtlenquiry@eaton.com

THE AMERICAS:

+1 800 835 7075 mtl-us-info@eaton.com

ASIA-PACIFIC:

+65 6 645 9888 sales.mtlsing@eaton.com

CPS BACKPLANE DIMENSIONS (mm)

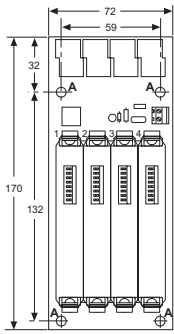

CPS04
CPS04-CC

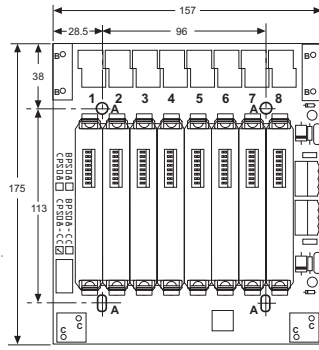

CPS08
CPS08-CC

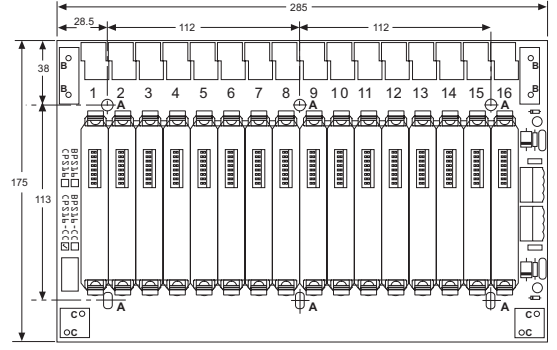

CPS16
CPS16-CC

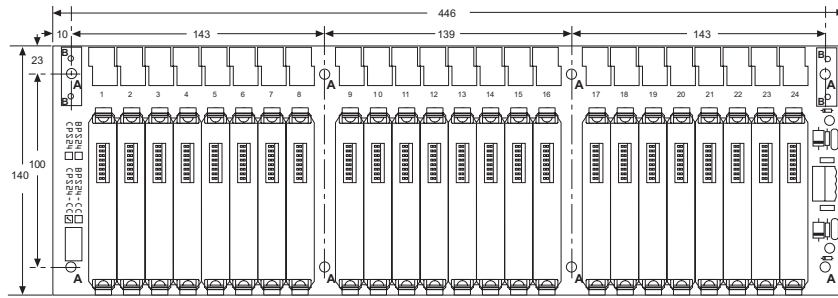

CPS24

-CC - Conformal Coating

Power requirements, Vs

21V dc to 35V dc through plug-in connectors

Safe-area connections

CPS: 2.5mm² screw-clamp terminals – 6 positions per module

Weight (without modules or accessories)

| | |
|--------|------|
| CPS04: | 96g |
| CPS08: | 225g |
| CPS16: | 419g |
| CPS24: | 592g |

HMP24 - 19" RACK MOUNTING PLATE FOR CPS24

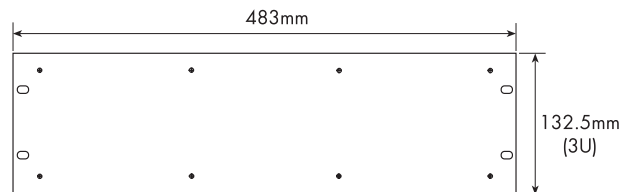

BACKPLANE ACCESSORIES

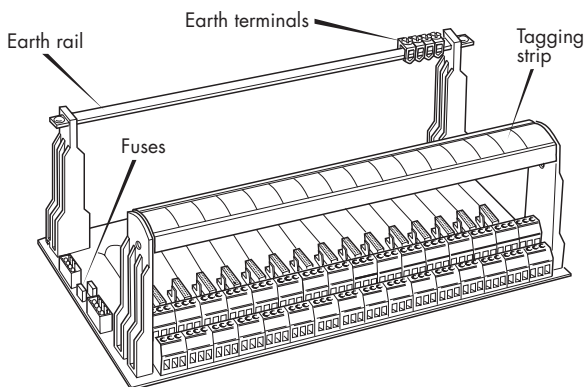

SCK45 - backplane clips



10 x strip of four

MCK45 - backplane clips



16 x strip of two

The given data is only intended as a product description and should not be regarded as a legal warranty of properties or guarantee. In the interest of further technical developments, we reserve the right to make design changes.



Powering Business Worldwide

Eaton Electric Limited,
Great Marlings, Butterfield, Luton
Beds, LU2 8DL, UK.
Tel: + 44 (0)1582 723633 Fax: + 44 (0)1582 422283
E-mail: mtlenquiry@eaton.com
www.mtl-inst.com

© 2016 Eaton
All Rights Reserved
Publication No.
EPS45/5500 Rev6 010916

EUROPE (EMEA):
+44 (0)1582 723633 mtlenquiry@eaton.com
THE AMERICAS:
+1 800 835 7075 mtl-us-info@eaton.com
ASIA-PACIFIC:
+65 6 645 9888 sales.mtlsing@eaton.com

CUSTOM BACKPLANES

MTL4500 range of backplanes can be customised for specific applications and customer's requirements. All the signals on the backplane are 'safe-area' so custom designs are possible without the need for certification. Eaton offers a fast and efficient customising service upon request.

Many installations can benefit from the use of existing custom solutions. These provide reduced system wiring, modularisation of the channels to match the IO card. In addition diagnostics, such as line fault detection, can be grouped prior to connection into the system.

Remote cable connections:

In addition to the many DCS solutions, listed on a previous page, are backplanes and cables that are ideal when the isolators are mounted in remote cabinets and the signals need to be returned to the system via a multicore cable.

CP-DYN RANGE

| FTA | Size | Function | MTL modules |
|---------------|------|------------------------------|----------------------|
| CP-DYNB-AIO | B | 16ch analogue input /output | MTL4541, 4546Y, 4573 |
| CP-DYNB-AI250 | B | 16ch analogue input 1-5V o/p | MTL4541, 4573 |
| CP-DYNA-2AIO | A | 16ch analogue input / output | MTL4544, 4549Y |
| CP-DYNB-DI | B | 16ch digital input | MTL4511, 4514 |
| CP-DYNB-DILF | B | 16ch digital input with LFD | MTL4514 |
| CP-DYNB-2DI | B | 32ch digital input | MTL4513, 4516, 4517 |
| CP-DYNB-4DI | B | 48ch digital input | MTL4510 |
| CP-DYNA-DO | A | 8ch digital output | MTL4521, 4521L |
| CP-DYNB-DO | B | 16ch digital output | MTL4521, MTL4521L |

DESCRIPTION

For use when the IS interfaces are remotely mounted from the control system, this series of cable connected FTAs provide a simple plug/socket connection method for IS field devices to any control system. The FTAs come fitted with mounting pillars for surface mounting or may be used with the DIN rail mounting kit to mount on a single DIN rail.

The cable connections between the system card and the FTA use the Tyco Dynamic range of connector which provide a reliable and high density solution.

CP-DYN DIMENSIONS

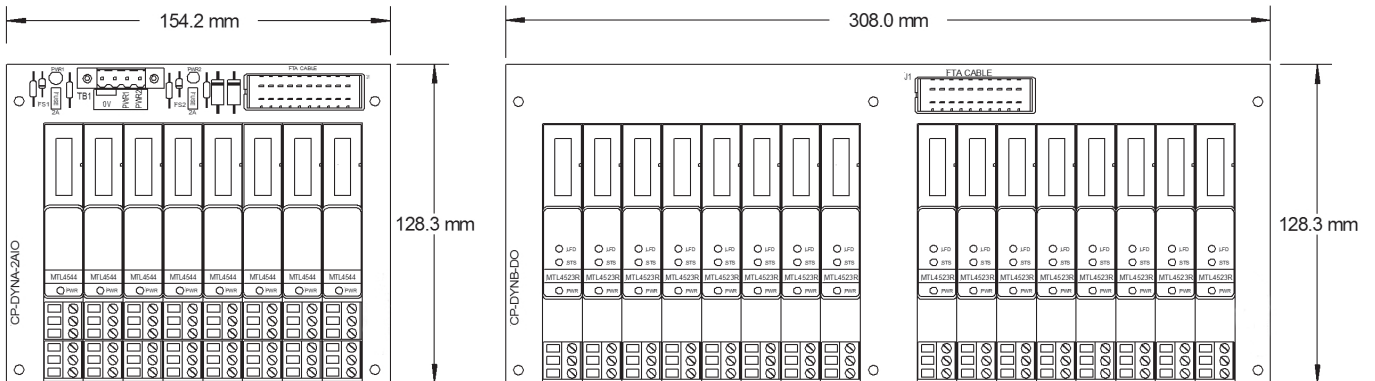

For full technical details please contact your local Eaton sales office.



CABLES

All FTAs use the Tyco 20 pin Dynamic range of connectors. Cables are fitted with a mating connector and free ends the other, for connection to the system card.

Cable ordering code

| | |
|--------------|------------|
| CABDYN20-0.5 | 0.5m cable |
| CABDYN20-1 | 1.0m |
| CABDYN20-2 | 2.0m |
| CABDYN20-3 | 3.0m |
| CABDYN20-5 | 5.0m |
| CABDYN20-8 | 8.0m |
| CABDYN20-10 | 10m |
| CABDYN20-15 | 15m |
| CABDYN20-20 | 20m |
| CABDYN20-25 | 25m |
| CABDYN20-30 | 30m |

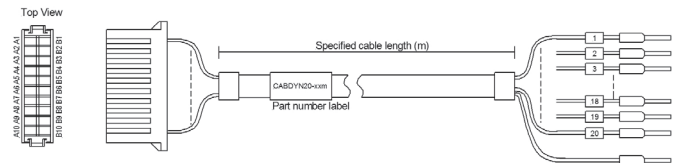

CPELCO RANGE

A range of dedicated backplanes to interface with MTL4500 range of intrinsically safe isolator modules and the MTL HART maintenance system products. The backplanes offer a standard Elco interface connector for use in systems where the IS interfaces are remote from the DCS.

| Backplane | Function | MTL module | Cable |
|------------|-----------------|------------------------------|------------|
| CPM08-2AIO | 16ch AI 4-20mA | MTL4544/4576/4549Y x 8 | Elco38 x 1 |
| CPM08-2AV | 16ch AI 1-5V | MTL4544/4576 x 8 | Elco38 x 1 |
| CPM16-AIO | 16ch AIO 4-20mA | MTL4541/4573/4546Y | Elco38 x 1 |
| CPM16-2AIO | 32ch AI 4-20mA | MTL4544/4576/4549Y x 16 | Elco38 x 2 |
| CPM16-2AV | 32ch AI 1-5V | MTL4544/4576 x 16 | Elco38 x 2 |
| CPM08-DDI | 16ch DI | MTL4513/4516 | Elco38 x 1 |
| CPM16-DO | 16ch DO | MTL4524/4523R | Elco38 x 1 |
| CGM08-DO | 8ch DO | MTL4521/4521L (loop powered) | Elco38 x 1 |

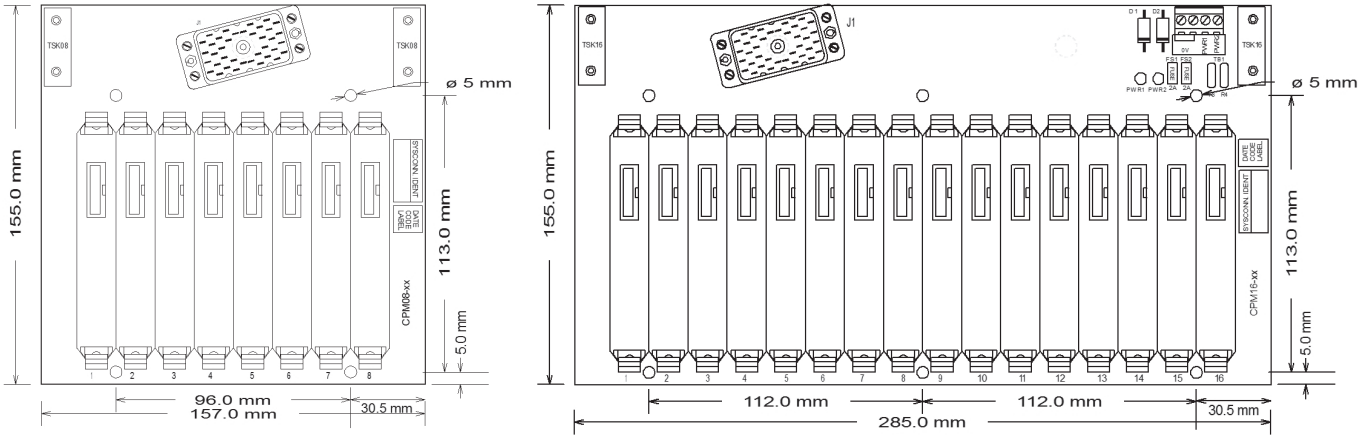

For full technical details please contact your local MTL sales office.

ANALOGUE SIGNAL REPEAT

CPS04-AIREP backplane may be used to generate a repeat output from a single transmitter source. This includes high integrity loops in general purpose applications. The MTL4641 is used to generate an isolated repeat signal from an existing 4-20mA loop.

CPS04-2AIO, 8 channel backplane, is used with IS signals with 2 channel AI or AO modules or with the MTL4544D to generate 4 inputs with repeat outputs.

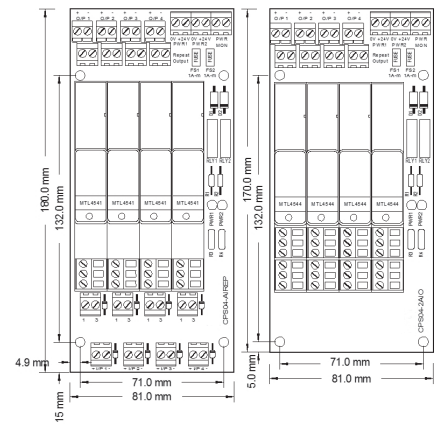

MTL CUSTOM BACKPLANE SOLUTIONS

A wide range of backplanes can be offered with application specific functions. System connection options and modularity for individual signal types can be provided to offer significant space and cost savings. Please contact your local Eaton sales office if you wish to discuss your application requirements.

PRODUCT MIGRATION

Migration options for legacy MTL4000 range installations are also available. This enables isolators to be easily upgraded, or re-connecting existing isolators to a new control system, with the minimum of disturbance to existing wiring. For more information on product migration visit the resource section at www.mtl-inst.com

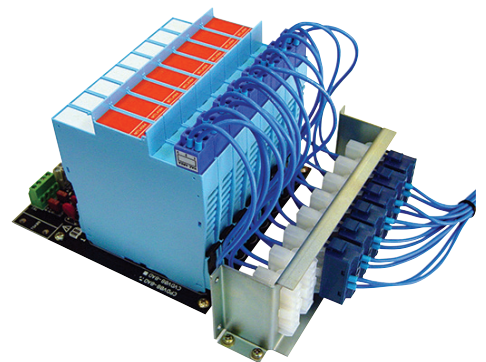

The given data is only intended as a product description and should not be regarded as a legal warranty of properties or guarantee. In the interest of further technical developments, we reserve the right to make design changes.



Eaton Electric Limited,
Great Marlings, Butterfield, Luton
Beds, LU2 8DL, UK.
Tel: + 44 (0)1582 723633 Fax: + 44 (0)1582 422283
E-mail: mtlenquiry@eaton.com
www.mtl-inst.com

© 2016 Eaton
All Rights Reserved
Publication No.
EPS45/5500 Rev6 010916

EUROPE (EMEA):
+44 (0)1582 723633 mtlenquiry@eaton.com
THE AMERICAS:
+1 800 835 7075 mtl-us-info@eaton.com
ASIA-PACIFIC:
+65 6 645 9888 sales.mtling@eaton.com

ORDERING INFORMATION



MTL4500/5500 range isolators

Specify part number: **eg, MTL4511, MTL5575**

Individual isolator identification

TH5000 Tag holder (Pack of 20)

Connectors - MTL4500 & MTL5500

HAZ1-3 Hazardous-area plug, terminals 1, 2 and 3

HAZ4-6 Hazardous-area plug, terminals 4, 5 and 6

HAZ-CJC Hazardous-area plug, terminals 1 and 3 with cold-junction sensor

HAZ-CJC2 Hazardous-area plug, terminals 4 and 6 with cold-junction sensor

SAF1-3 Safe-area plug, terminals 1, 2 and 3

SAF4-6 Safe-area plug, terminals 4, 5 and 6

Connectors - MTL5500 only

SAF7-9 Safe-area plug, terminals 7, 8 and 9

SAF10-12 Safe-area plug, terminals 10, 11 and 12

PWR5000 Power connector, terminals 13 and 14

PowerBus - MTL5500 only

PB-8T Powerbus Kit for up to 8 isolators

PB-16T Powerbus Kit for up to 16 isolators

PB-24T Powerbus Kit for up to 24 isolators

PB-32T Powerbus Kit for up to 32 isolators

MTL5500 mounting accessories

THR2 1m length of DIN rail to EN 50022; BS 5584; DIN 46277

MS010 DIN-rail module spacer, 10mm (pack of 5)

MTL5500 earth-rail and tag strip accessories

IMB57 Insulating mounting block

ERB57S Earth-rail bracket, straight

ERL7 Earth-rail, 1m length

ETM7 Earth terminal, bag of 50

TAG57 Tagging strip, 1m length

TGL57 Tagging strip labels, set of 10 x 0.5m

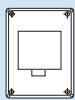

MTL5500 enclosures

DX070 Enclosure for MTL5500 x 4

DX170 Enclosure for MTL5500 x 10



MTL4500 standard backplanes

CPS04 4-way backplane screw-clamp connector

CPS08 8-way backplane screw-clamp connector

CPS16 16-way backplane screw-clamp connector

CPS24 24-way backplane screw-clamp connector

MTL4500 custom backplanes

Contact your local Eaton sales office for options and advice



MTL4500 backplane mounting accessories

DMK01 DIN-rail mounting kit, T- or G-section (pack of 40)
8-way backplanes require 4,
16-way backplanes require 6

SMS01 Surface mounting kit (pack of 40)
4- and 8-way backplanes require 4,
16-way backplanes require 6,
24-way backplanes require 8

HMP24 Horizontal mounting plate and screws for 19-inch rack mounting
24-way backplanes only

BMK08 Mounting kit for one 4- or 8-way backplane

BMK16 Mounting kit for one 16-way backplane

MTL4500 backplane accessories

ERK08 Earth rail kit for CPS08 backplane

ERK16 Earth rail kit for CPS16 backplane

TSK08 Tagging strip kit for CPS08 backplane

TSK16 Tagging strip kit for CPS16 backplane

TSK24 Tagging strip kit for CPS24 backplane

FUS1.0ATE5 Fuse kit, 1.0A (pack of 10)

FUS2.0ATE5 Fuse kit, 2.0A (pack of 10)

FUS2.5ATE5 Fuse kit, 2.5A (pack of 10)

FUS4.0ATE5 Fuse kit, 4.0A (pack of 10)

MCK45 MTL4000 backplane conversion kit (16 clip pairs per pack)

SCK45 Module 4-clip strips (10 strips + 40 rivets per pack)

MPL01 Module position label (blank) (50 per pack)

MCC45 Module backplane connector cover (pack of 50)



Literature

INM5500 MTL5500 range instruction manual

INM4500/4600 MTL4500/MTL4600 range instruction manual

Configurator and software

PCL45USB Configurator, PC interface and software

PCS45 PC software

Please go to our website at www.mtl-inst.com for the latest information regarding safety approvals, certificates and entity parameters.



Powering Business Worldwide

Eaton Electric Limited,
Great Marlings, Butterfield, Luton
Beds, LU2 8DL, UK.
Tel: + 44 (0)1582 723633 Fax: + 44 (0)1582 422283
E-mail: mtlenquiry@eaton.com
www.mtl-inst.com

© 2016 Eaton
All Rights Reserved
Publication No.
EPS45/5500 Rev6 010916

EUROPE (EMEA):
+44 (0)1582 723633 mtlenquiry@eaton.com
THE AMERICAS:
+1 800 835 7075 mtl-us-info@eaton.com
ASIA-PACIFIC:
+65 6 645 9888 sales.mtlsing@eaton.com